

TECHNICAL MANUAL

**ORGANIZATIONAL, DIRECT SUPPORT, GENERAL SUPPORT, AND
DEPOT MAINTENANCE MANUAL**

**TEST SET, STABILIZATION EQUIPMENT TS-1894/ASM
(PART NO. 114E5987-4, NSN 4920-00-959-6125)
(PART NO. 114E5987-8, NSN 4920-00-133-7834)**

**This copy is a reprint which includes current pages from
Changes 1 through 4. The title was changed to read as
shown above by Change 4.**

CAUTION

THIS EQUIPMENT IS TRANSISTORIZED

Observe all precautions to prevent transistor damage. Make resistance measurements in the equipment only as specified.



**ORGANIZATIONAL, DIRECT SUPPORT, GENERAL SUPPORT,
 AND DEPOT MAINTENANCE MANUAL
 TEST SET, STABILIZATION EQUIPMENT TS-1894/ASM
 (PART NO. 114E5987-4. NSN 4920-00-959-6125)
 (PART NO. 114E5987-8. NSN 4920-00-133-7834)**

		Page
SECTION I.	INTRODUCTION AND DESCRIPTION	
1-1	General	1
1-2	Scope	1
1-2.1	Indexes of publications	1
1-2.2	Forms and records	1
1-2.3	Reporting of errors	1
1-2.4	Reporting of equipment improvement recommendation (EIR)	1
1-2.5	Administrative storage	1
1-2.6	Destruction of Army electronics materiel	1
1-3	Purpose of equipment	1
1-5	Adapter switch operation	2
1-5.1	Items comprising an operable equipment	2
1-6	Description of equipment	2
1-12	Theory of operation	3
1-14	Channel test circuits	3
1-15	Roll channel	3
1-16	Pitch channel	4
1-17	Yaw channel	4
1-18	Actuator simulator	5
1-21	Phase inverter	5
1-22	Chopper.....	6
1-23	Preamplifier and filter	6
1-24	Amplifier	7
1-25	Axis meter rectifier	7
1-26	External card test circuits	8
1-27	Demodulator-modulator card test circuit	8
1-28	Amplifier card	9
1-29	Amplifier card test circuit	10
1-30	Function meter circuits	13
1-31	Dc metering circuits	13
1-32	Ac metering circuits	14
1-33	Function meter rectifier	14
1-34	Miscellaneous test circuits	14
1-35	ASE mode	14
1-36	Half-gain mode.....	14
1-37	Power supplies	15
1-38	Ac power circuit.....	15
1-39	Dc power circuit	15
1-40	Pneumatic system	15
II.	SPECIAL SERVICE TOOLS	
2-1	Special service tools	23
III.	PREPARATION FOR USE, STORAGE, OR SHIPMENT	
3-1	Unpacking and inspection	25
3-2	Preparation for use	25
3-3	Preparation for storage	25
3-4	Preparation for shipment	25
IV.	OPERATING INSTRUCTIONS	
4-1	General	27
4-3	SAS component tests	27

	Page
SECTION IV.	
4-4 Preliminary procedures	27
4-6 SAS amplifier testing procedures	27
4-8 Channel tests using a rate table	27
4-9 Airspeed and sideslip tests	31
4-10 ASE mode tests	32
4-11 Excitation voltage tests	32
4-12 Interlock voltage tests	32
4-13 Pedal position variable resistor feedback voltage test	32
4-14 Internal test circuits	32
4-15 Printed-wiring circuit board (card) tests	33
4-17 Demodulator-modulator card	33
4-18 Amplifier card	33
4-19 Calibration card	33
4-20 Stopping procedure	33
4-22 Use of connector tools	35
V. PERIODIC INSPECTION, MAINTENANCE AND LUBRICATION	
5-1 Scope of maintenance	39
5-2 Preventive maintenance	39
5-2.1 Systematic care	39
5-2.2 Preventive maintenance checks and services	39
5-2.3 Preventive maintenance checks and services periods	39
5-2.4 Daily preventive maintenance checks and services chart	40
5-2.5 Weekly preventive maintenance checks and services chart	41
5-2.6 Quarterly preventive maintenance checks and services chart	41
5-2.7 Cleaning	43
5-2.11 Touchup painting	43
5-3 Lubrication	43
5-4 Adjustments	43
VI. TROUBLESHOOTING AND PARTS REPLACEMENT	
6-1 Troubleshooting procedures	45
6-2 General	45
6-3 Test equipment required	45
6-4 Troubleshooting tables	45
6-5 Parts replacement	45
6-7 Replacement of air pump assembly	45
6-8 Replacement of regulator valves	45
6-9 Replacement of tube assemblies	49
6-10 Replacement of air gages	49
6-11 Replacement of printed circuit cards	53
6-12 Repairs	53
6-13 Card repairs	53
6-14 Connector repairs	58
6-15 Selection of values for actuator simulator card capacitor C607 and resistor R648	58
6-16 Selection of value for amplifier card resistor R9	60
VII. DEPOT OVERHAUL STANDARDS	
7-1 Applicability of depot overhaul standards	65
7-2 Applicable references	65
7-3 Test facilities required	65
7-4 Preliminary procedures	65
7-5 Ac power supply circuit and meter rectifier circuit test	65
7-6 Dc power supply circuit test	66
7-7 Metering circuit tests	66
7-8 Actuator simulator tests	67
7-9 Internal amplifier card circuit test 70	70
7-10 External AMPLIFIER CARD TESTER circuit test	70
7-11 External DEM/MOD CARD TESTER circuit test	70
7-12 Half-gain circuits test	71
7-13 Pneumatic components test	71
7-14 Adapter circuits test	71
7-15 Stopping procedures	72
APPENDIX I. REFERENCES	75
II. BASIC ISSUE ITEMS LIST (BIIL) AND ITEMS TROOP INSTALLED OR AUTHORIZED LIST (ITIAL) (Not Applicable)	
III. MAINTENANCE ALLOCATION	79
IV. ILLUSTRATED PARTS BREAKDOWN	83

Figure No.	LIST OF ILLUSTRATIONS	Page
1-1	SAS bench test set	iv
1-1.1	SAS bench test set adapter	v
1-2	Actuator-simulator card, schematic diagram	11
1-3	Amplifier card, schematic diagram	13
1-4	Function meter circuits, simplified schematic	15
1-5	Test Set, schematic diagram	15
1-6	Pneumatic system, schematic diagram	16
1-7	Adapter, schematic	17
3-1	Test set with mounting studs extended	26
4-1	Front panel, test set	28
4-2	Test setup	32
4-3	Connector contact tools	34
6-1	SAS bench test set, wiring diagram	53
6-2	Actuator-simulator card, wiring diagram	54
6-3	Amplifier card, wiring diagram	55
6-4	Adapter, wiring diagram	56
6-5	Left-rear view, SAS bench test set	57
6-6	Actuator-simulator card, test setup	58
6-7	Balance resistors location	59
7-1	Test device, simulated torque motor voltages	68
9-1	SAS bench test set, exploded view (sheet 1)	83
9-1	SAS bench test set, exploded view (sheet 2)	84
9-1	SAS bench test set, exploded view (sheet 3)	85
9-2	SAS bench test set component boards (sheet 1)	93
9-2	SAS bench test set component boards (sheet 2)	94
9-3	SAS bench test adapter	102

Table No.	LIST OF TABLES	Page
1-1	Equipment supplied	2
4-1	Controls	29
4-2	Indicators	30
4-3	Receptacles	31
4-4	Voltages at main connector test points	35
6-1	Meter test circuit troubleshooting	46
6-2	Internal and external card test circuit troubleshooting	49
6-3	Miscellaneous test circuit troubleshooting	50
6-4	DC resistance of transformers	53
6-5	Equipment required to fabricate test setup	60
7-1	AIRSPEED indicator test	71
7-2	DIFF. PRESSURE indicator test	71

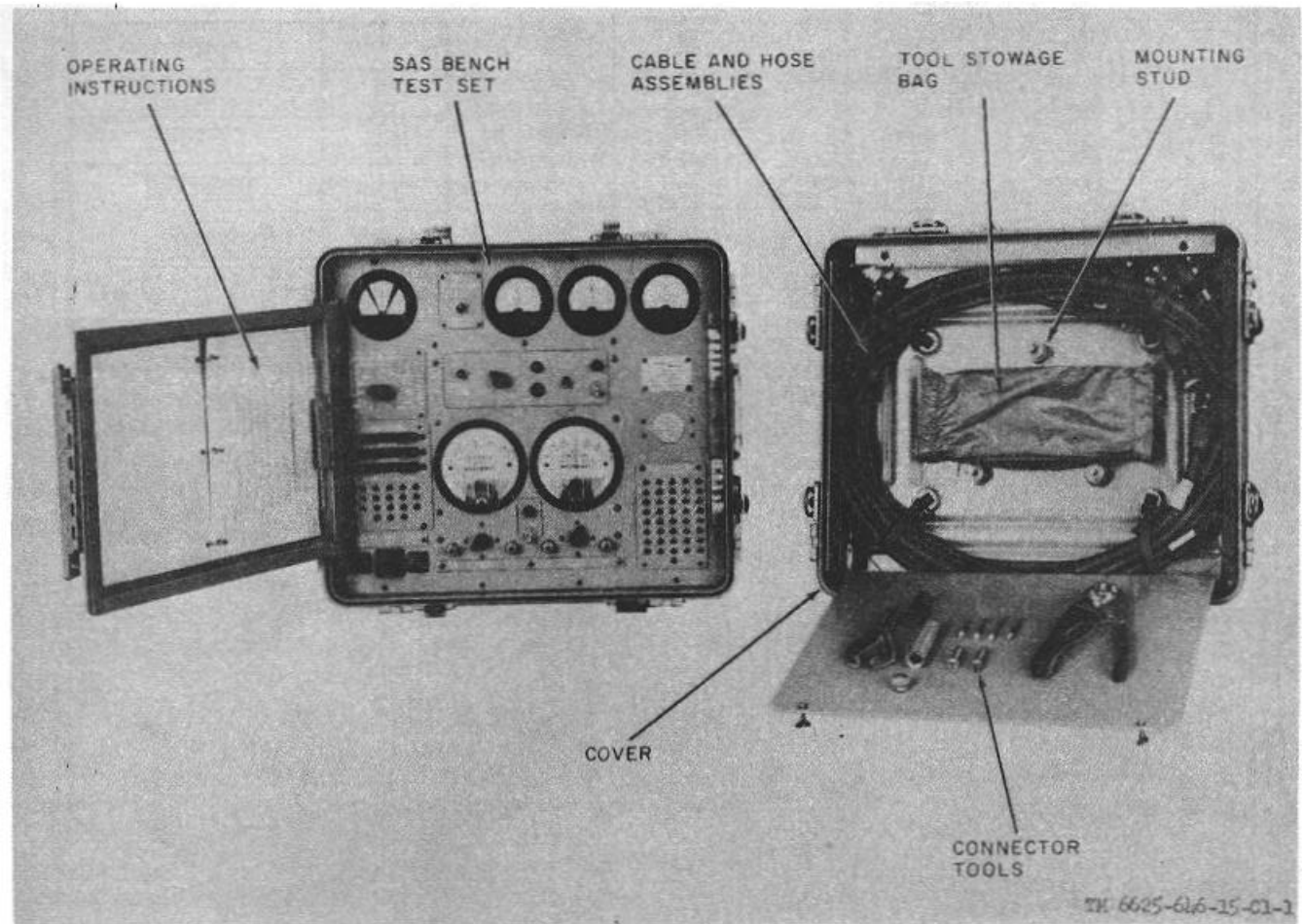

Figure 1-1. SAS bench test set.

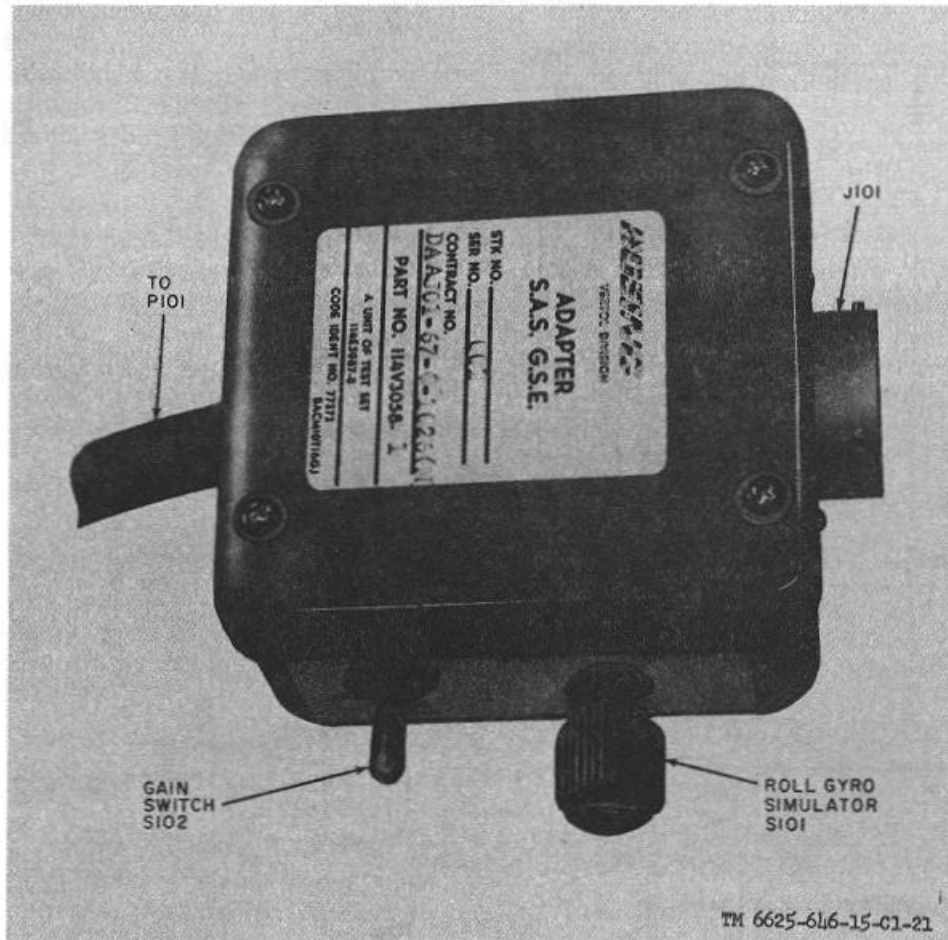

Figure 1-1.1 SAS bench test set adapter.

SECTION I INTRODUCTION AND DESCRIPTION

1-1. General

1-2. Scope

This manual describes Test Set, Stabilization Equipment TS-1894/ASM (fig. 1-1) and provides instruction for operation, maintenance, and functioning of the equipment. It includes the maintenance allocation chart and illustrated parts breakdown. Unless otherwise indicated, all references to the TS-1894/ASM apply to SAS Bench Test Set part Nos. 114E5987-4 and 114E5987-8.

1-2.1. Indexes of Publications

a. *DA Pam 310-4.* Refer to the latest issue of DA Pam 310-4 to determine whether there are new editions, changes, or additional publications pertaining to the equipment.

b. *DA Pam 310-7.* Refer to DA Pam 310-7 to determine whether there are modification work orders (MWO's) pertaining to the equipment.

1-2.2. Forms and Records

a. *Reports of Maintenance and Unsatisfactory Equipment.* Maintenance forms, records, and reports which are to be used by maintenance personnel at all maintenance levels are listed in and prescribed by TM 38-750.

b. *Report of Packaging and Handling Deficiencies.* Fill out and forward DD Form 6 (Packaging Improvement Report) as prescribed in AR 70058/NAVSUPINST 4030.29/AFR 71-13/MCO P4030.29B, and DLAR 4145.8.

c. *Discrepancy in Shipment Report (DISREP) (SF 361).* Fill out and forward Discrepancy in Shipment Report (DISREP) (SF 361) as prescribed in AR 55-38/NAVSUPINST 4610.33B/AFR 75-18/MCO P4610.19C and DLAR 4500.15.

1-2.3. Reporting of Errors

You can help improve this manual by calling attention to errors and by recommending improvements and stating your reasons for the recommendations. Your letter or DA Form 2028 (Recommended Changes to Publications and Blank Forms) should be mailed direct to Commander, US Army Communications & Electronics Materiel Readiness Command, ATTN: DRSEL-MA-Q, Fort Monmouth, NJ 07703. A reply will be furnished direct to you.

1-2.4. Reporting Equipment Improvement Recommendations (EIR)

EIR's will be prepared using DA Form 2407, (Maintenance Request). Instructions for preparing EIR's are provided in TM 38-750, the Army Maintenance Management System. EIR's should be mailed direct to Commander, US Army Electronics Command, ATTN: DRSEL-MA-Q, Fort Monmouth, NJ 07703. A reply will be furnished direct to you.

1-2.5. Administrative Storage

Administrative storage of equipment issued to and used by Army activities shall be in accordance with TM 740-90-1.

1-2.6. Destruction of Army Electronics Materiel

Destruction of Army electronics materiel to prevent enemy use shall be in accordance with TM 750-244-2.

1-3. Purpose of Equipment

1-4.

The test set tests the Stability Augmentation System (SAS) amplifier installed in CH-47 helicopters. The test set determines that a SAS amplifier or its plug-in cards perform according to minimum serviceability standards. Test cables and receptacles and air pressure connections are provided for SAS amplifier tests. In test set 114E5987-8, adapter 114V3058-1 (roll gyro simulator) is provided. Three CARD TESTER receptacles, marked DEM/MOD, AMPLIFIER, and CALIBRATION, are installed on the front panel. In addition, test points (test jacks) are provided for measuring input, output, and signal voltages at the receptacle of the SAS amplifier. Test jacks are also provided for measuring resistances or checking relay operation on its plug-in calibration card.

1-5. Adapter Switch Operation

An adapter switch is located behind a warning instruction panel on the front panel. The switch is factory-set at B for testing CH-47 SAS amplifiers. Position A is used for testing SAS amplifiers for other helicopters. Operating the switch from B to A transposes the pitch and roll channel circuits of the test set. It also changes the amplifier operating voltage output of the test set from 115 to 26 volts ac.

1-5.1. Items Comprising an Operable Equipment

NSN	Qty	Nomenclature, part no., and mfr code	Usable on code	Fig. No.
NOTE				
The part number is followed by the applicable 5 digit Federal supply code for manufacturers (FSCM) identified in SB 708-42 and used to identify manufacturer, distributor, or Government agency, etc.				
NOTE				
A number 1 in the usable on code column refers to items comprising an operable TS-1894/ASM: 114E59874; number 2 refers to items comprising an operable TS-1894/ASM: 114E5987-8.				
4920-00-959-6125		Test Set, Stabilization Equipment TS-1894/ASM: 114E5987-4; 77272 (This item is nonexpendable)		
4920-00-133-7834		Test Set, Stabilization Equipment TS-1894/ASM: 114E5987-8; 77272 (This item is nonexpendable) consisting of:		
661500-133-7838	1	Adapter, Test Set: 114V3058-1; 77272	2	1-1.1
5995-00-9091913	1	Cable Assembly, Special Purpose: 10-359134-1; 77820	1, 2	1-1, 9-1
5995-00-9091915	1	Cable Assembly, Special Purpose: 10-359141-1; 77820	1, 2	1-1, 9-1
599500-906-6403	1	Cable Assembly, Special Purpose: 10-359142-1; 77820	1, 2	1-1, 9-1
4730-00-684-0738	4	Coupling, Hose, Quick Disconnect: 1011-4; 00624; A02VS311-2; 77272	1, 2	9-1
4720-00-720-0294	4	Hose Assembly: AN6270-4-42; 88044	1, 2	1-1
	1	Operating Instructions: SSE500-3; 77272	1	1-1
	1	Operating Instructions: SSE500-3, Dated I May 1969; 77272	2	1-1
5120-00-083-5019	1	Positioner, Contact: 11-7771-5; 77820	1, 2	1-1, 9-1
5120-00-083-5020	1	Positioner, Contact: 11-7771-6; 77820	1, 2	1-1, 9-1
5120-00-765-3688	1	Removal Kit, Contact: 11-6900; 77820	1, 2	1-1, 9-1
5120-00-765-3189	1	Tool, Contact Insertion: 11-6782; 77820	1, 2	1-1, 9-1
5120-00-8563732	1	Tool, Crimping: MS3191-1; 96096	1, 2	1-1, 9-1
6625-00-9181850	1	Bag Assembly Storage: A02VS310-1; 77272	1, 2	1-1, 9-1

1-6. Description of Equipment

1-7. (fig. 1-1). The test set is contained in a two-piece combination case. The case is airtight and watertight. The cover of the case houses interconnecting cables, power cables, and special tools and in the -8 test set, the adapter. Operating instructions for the test set are mounted on a retainer assembly. The assembly is attached to the operating panel with hinged latch assemblies. The retainer assembly can be swung to either side or completely removed when the test set is used. All components are mounted on a panel-chassis assembly secured to the bottom of the case. A manually operated relief valve is installed in the cover. The valve permits equalizing test set air pressure to atmosphere. The cover can be latched to the bottom of the test set. Three retractable studs on the cover permit mounting the test set on the back panel of a workbench. All controls, receptacles, indicators, and test jacks are on the front panel. All are identified.

1-8. The test set incorporates seven plug-in component cards. Three of these are actuator simulator cards A02V3048. The fourth card A02V3060, the fifth card

A02V3064, and the sixth 2 Change 4 card A02V3068, contain power supply components, load resistors, meter multiplier resistors, and miscellaneous components. The seventh card, 114E3040-47 is a four-stage amplifier. This card is part of the demodulator-modulator card test circuit. It is identical with the amplifier card used in the SAS amplifier.

1-9. The test set incorporates four test meters. The function meter indicates ac or dc voltages at the circuit points selected by the FUNCTION switch. YAW, ROLL, and PITCH AXIS meters indicate the open-loop output of the corresponding SAS amplifier channel or the simulated feedback output of the actuator simulator card in the channel test circuit.

1-10. An electrically operated air pump provides ram and differential air pressures for checking the airspeed and sideslip circuits in the SAS amplifier. Ram air pressure is connected to the test set P (pitot) and S (static) fittings. Differential air pressure is connected to the test set L (left) and R (right) fittings. An AIRSPEED REG valve controls the ram air pressure.

An AIRSPEED indicator, calibrated in knots, indicates the air pressure applied to the SAS amplifier airspeed sensor. A DIFF PRESS REG valve controls the amount and direction of differential air pressure. A DIFF PRESSURE indicator, calibrated in inches of water, indicates the amount and direction of the differential pressure applied to the SAS amplifier sideslip sensor.

Table 1-1. Equipment Supplied

Quantity	Item description	Part number
1	SAS bench test set	114E5987-4,-8
1	Bag assembly	A02VS301-1
1	Cable assembly	A02VS309-1
1	Cable assembly	A02VS309-2
1	Cable assembly	A02VS309-3
1	Contact insertion tool	11-6782
1	Contact positioner	11-7771-5
1	Contact positioner	11-7771-6
1	Contact removal kit	11-6900

Table 1-1. Equipment Supplied - Continued

Quantity	Item description	Part number
1	Crimping tool	MS3191-1
4	Hose assemblies	AN6270-4-42
1	Operating instructions	SSE-500-3
4	Quick-disconnect couplings ..	A02VS311-2
1	Adapter assembly (P/O test... set 114E5987-8).	114V3058-1

1-10.1 (fig. 1-1.1). The adapter includes a 5-position ROLL GYRO SIMULATOR switch and a GAIN SWITCH. The ROLL GYRO SIMULATOR switch provides a signal simulating the helicopter vertical gyro roll signal. The GAIN SWITCH controls the pitch channel gain relay, simulating the landing gear switch.

1-11. The physical dimensions and weight of the test set are as follows:

- a .. Length 17.75 inches
- b .. Height 12.83 inches

- c. .. Width..... 20.75 inches
- d. .. Weight 63.25 pounds

1-12. Theory of Operation

1-13. The test set consists of essentially independent circuits which simulate signals normally produced by the extensible links, the pitot-static system, and the yaw (sideslip) ports in the helicopter. The test set includes circuits to check the output of each channel of the SAS amplifier, the demodulator-modulator card, the amplifier card, the metering circuits, and the half-gain mode circuit. An ASE mode test circuit is not used for CH-47 SAS amplifiers. Each channel test circuit includes an actuator simulator card. The demodulator-modulator card test circuit includes an amplifier card. The test set also contains ac and dc power supplies and a pneumatic system. The power supplies enable operation of the test set and the SAS amplifier circuits. The pneumatic system enables testing of airspeed and sideslip circuits. Refer to figure 1-2 for the schematic diagram of the actuator-simulator card. Refer to figure 1-3 for the schematic diagram of the amplifier card. Refer to figure 1-4 for the schematic diagram of the function meter circuits. Refer to figure 1-5 for the overall schematic diagram of the test set. Refer to figure 1-6 for the pneumatic system schematic. Refer to figure 1-7 for the adapter schematic.

1-14. Channel Test Circuits

1-15. Roll Channel

(figs. 1-5 and 1-7)

The roll channel test circuit measures the open and closed loop channel output of a SAS amplifier under test.

a. The channel output signal is connected to pins R, S, and T of receptacle J60. From here the signal is connected through pins 2, 3 (dc common), and 5 of receptacle J64 to the phase inverter stage of the actuator-simulator card. The differential output of the SAS amplifier channel at pins 2 and 5 is also connected by jumper wires to pins 21 and 24 of receptacle J64. Only one of these simulator card input circuits is active, depending on the mode of test set operation selected by AXES METERS READ switch S4.

b. During open loop testing, the channel output is routed directly through a meter multiplier resistor and relay contacts to the metering circuit output of the actuator-simulator card at pins 20 and 23 of receptacle J64.

c. During closed loop testing, the channel output is converted to a positive or negative dc voltage, chopped, converted to a nominal sine wave, amplified, and fed back to the SAS amplifier as a simulated feedback signal (para 1-18 through 1-25). This simulated feedback signal is also rectified on the actuator-simulator card and connected through relay contacts to the metering circuit output at pins 20 and 23 of receptacle J64.

d. The open or closed loop metering circuit output of the actuator-simulator card from receptacle J64 pins 20 and 23 is routed to ROLL AXIS meter M3 through adapter switch S5.

e. The feedback signal output of the actuator-simulator card from receptacle J64 pin 25 is routed to jumpered pins U and W of receptacle J60. From this point, the signal is routed to the SAS amplifier feedback (cancellation) circuits.

f. The 2.5-volt ac feedback resistor excitation voltage from the SAS amplifier channel is connected to pins V and X of receptacle J60. From pins V and X the excitation voltage is connected to the reference voltage input of the actuator-simulator card at pins 8 and 9 of receptacle J64. On the actuator-simulator card, the excitation voltage is used to phase-relate the operation of a chopper stage to the operation of the SAS amplifier channel (para 1-22). The excitation voltage is also connected to the ac metering circuits through the ROLL (or PITCH) FEEDBACK POT. EXCITATION position of FUNCTION switch S7 (para 132).

g. From pins p of SAS amplifier receptacle J1 and adapter receptacle J101, 26 volts ac is connected to the primary of adapter transformer T101. A primary tap supplies approximately 13-volt ac to SAS amplifier roll signal demodulator Q302. The secondary of T101 is connected through dropping resistors R101

through R104 to contacts of ROLL GYRO SIMULATOR switch S101. Operating switch S101 to its two L or R positions connects phase-related operating voltages to SAS amplifier roll signal demodulator Q302 and limiter AR301. These voltages simulate the helicopter vgi roll signals.

1-16. Pitch Channel

(figs. 1-5 and 1-7)

The pitch channel test circuit measures the open and closed loop channel output of a SAS amplifier under test.

a. The channel output signal is connected to receptacle J60 pins Y, Z, and a. From here the signal is connected through receptacle J65 pins 2, 3 (dc common), and 5 to the phase inverter stage of the actuator-simulator card. The differential output of the SAS amplifier channel at pins 2 and 5 is also connected to jumpered pins 21 and 24 of receptacle J65. Only one of these simulator card input circuits is active, depending on the mode of test set operation selected by AXES METERS READ switch S4.

b. During open loop testing, the channel output is routed directly through a meter multiplier resistor and relay contacts to the metering circuit output of the actuator-simulator card at pins 20 and 2t of receptacle J65.

c. During closed loop testing, the channel output is converted to a positive or negative dc voltage, chopped, converted to a nominal sine wave, amplified, and fed back to the SAS amplifier as a simulated feedback signal (para 1-18 through 1-25). This simulated feedback signal is also rectified on the actuator-simulator card and connected through relay contacts to the metering circuit output at pins 20 and 23 of receptacle J65.

d. The open or closed loop metering circuit from receptacle J65 pins 20 and 23 is routed to PITCH AXIS meter M4 through adapter switch S5.

e. The feedback signal output from receptacle J65 pin 25 is routed to jumpered pins b and d of receptacle J60. From this point, the signal is routed to the SAS amplifier feedback (cancellation) circuits.

f. The 2.5-volt ac feedback component excitation voltage from the SAS amplifier channel is connected to receptacle J60 pins c and e. From pins c and e the excitation voltage is connected to the reference voltage input of the actuator-simulator card at receptacle J65 pins 8 and 9. Here, the excitation voltage is used to phase relate the operation of the SAS amplifier channel (para 1-22). The excitation voltage is also connected to the ac metering circuits through the PITCH (or ROLL) FEEDBACK POT. EXCITATION position of FUNCTION switch S7 (para 1-32).

g. With adapter GAIN SWITCH S102 at AIR, the base of pitch gain control switch Q303 (in the SAS amplifier) is grounded through pins B of adapter receptacle J101 and SAS amplifier receptacle J1. This cuts off Q303 and provides full output of pitch rate gyro RG1 as in SAS flight operation. With GAIN SWITCH S102 at GRD, ground return is open and switch Q303 conducts shunting 40 percent of the pitch output as in SAS ground operation.

1-17. Yaw Channel

(fig. 1-5)

The yaw channel test circuit measures the open closed loop channel output of a SAS amplifier under test.

a. The channel output signal is connected to pins H, J, and K of receptacle J60. From here the signal is connected through pins 2, 3 (dc common), and 5 of receptacle J63 to the phase inverter stage of the actuator-simulator card. The differential output of the SAS amplifier channel at pins 2 and 5 is also connected by jumper wires to pins 21 and 24 of receptacle J63. Only one of these actuator-simulator card input circuits is active, depending on the mode of test set operation selected by AXES METERS READ switch S4.

b. During open loop testing, the channel output is routed directly through a meter multiplier resistor and relay contacts to the metering circuit output of the actuator-simulator card at pins 20 and 23 of receptacle J63.

c. During closed loop testing, the channel output is converted to a positive or negative

voltage, chopped, converted to a nominal sine wave, amplified, and fed back to the SAS amplifier as a simulated feedback signal (para 1-18 through 1-25). This simulated feedback signal is also rectified on the actuator-simulator card and connected through relay contacts to the metering circuit output at pins 20 and 23 of receptacle J63.

d. The open or closed loop metering circuit output of the actuator-simulator card from pins 20 and 23 of receptacle J63 is routed to YAW AXIS meter M2.

e. The feedback signal of the actuator-simulator card from pin 25 of receptacle J63 is routed to pins L and N (strapped) of receptacle J60. From this point, the signal is routed to the feedback (cancellation) circuits of the SAS amplifier.

f. The 2.5-volt ac feedback resistor excitation voltage from the SAS amplifier channel is connected to pins M and P of receptacle J60. From pins M and P the excitation voltage is connected to the reference voltage input of the actuator-simulator card at pins 8 and 9 of receptacle J63. On the actuator-simulator card, the excitation voltage is used to phase relate the operation of the chopper stage to the operation of the SAS amplifier channel (para 1-22). The excitation voltage is also connected to the ac metering circuits through the YAW FEEDBACK POT. EXCITATION position of FUNCTION switch S7. (para 1-32).

1-18. Actuator Simulator

1-19. (fig. 1-2). The actuator simulator is a plug-in printed-wiring circuit board (card) designed to simulate a SAS extensible link as well as certain other actuators.

As the actuator-simulator is used in the SAS bench test set, two of the stages on the card are not operational and are not described:

- a. Demodulator CR613, CR614
- b. Output emitter-follower Q607

1-20. In addition to the two unused stages, certain resistors and input and output wiring options are not used and are not described. In the following stage analyses circuit and component functions are described to cover the operation of the circuit board when it is used to simulate an extensible link.

1-21. Phase Inverter (fig. 1-2)

In the unity-gain phase inverter, the output of the SAS amplifier channel is converted to a dc , signal voltage whose polarity is determined by the direction of the differential current output of the channel. Dc signal voltage from the phase inverter is chopped and fed to the two-stage preamplifier. The phase inverter stage includes a regulated - 20-volt dc supply.

a. The phase inverter is essentially a bridge circuit; resistors R613 and R615 are the two fixed elements. The input network consisting of resistors R605, R606, and R608 and transistor Q601 shunted by resistors R609 and R610 are the two dynamic elements. The adjustment of balance resistor R609 establishes the output of the phase inverter at zero volt when the output of the SAS amplifier channel is not differential.

b. The load resistors of the phase inverter present to the SAS amplifier channel a load equivalent to the torque motor (solenoid) of the extensible link. The output of the channel is connected through pins 2 and 5 of the card connector to load resistors R605 and R606 which simulate the windings of the link solenoid. Link operating voltage (approximately 15 volts dc) from the SAS amplifier is connected through pin 3 of the card connector to the junction of the load resistors.

c. When a correction signal is present in the SAS amplifier channel, the differential current output of the SAS amplifier causes voltage changes, which are equal and opposite, at the ends of the load resistors.

Depending on the direction of the differential current, the voltage on the base of transistor Q601 will increase or decrease, changing the collector current of the transistor accordingly. The voltage at the collector will change by an amount equal to the input but in the opposite direction.

d. The dc signal output of the phase inverter at the junction of resistors R613 and R615 is connected through an external jumper between pins 6 and 7 (which shunts resistor R614) of the card connector to a lag network consisting of resistor R617 and capacitor C601. This lag network reduces the rate of change in signal level, simulating the lag in actual link operation. A dual limiter consisting of diodes CR605 and CR606 limits the excursion of the dc signal to approximately ± 0.5 volt. The dual limiter protects against a high voltage condition which might result from a fault in the phase inverter or a fault in the SAS amplifier. Resistors R618 and R624 isolate the chopper from the phase inverter and the preamplifier.

e. Twenty-six volts ac from the power supply of the test box is applied through pin 19 of the card connector and is limited, rectified, filtered, and regulated to -20 vdc by the network consisting of resistor R625, rectifier diode CR608, capacitor C602, resistor R619 and zener diode CR607. Operating voltage is supplied to the collector of transistor Q601 through limiting resistor R616. Forward bias is applied to the base through fixed resistor R610 and balance resistor R609.

1-22. Chopper (fig. 1-2)

The chopper converts the dc output of the phase inverter to a positive or negative square wave, depending upon the polarity of the output. Feedback resistor excitation voltage from the SAS amplifier channel is used as a reference voltage to phase-relate the operation of the chopper to the operation of the channel.

a. The 2.5-volt ac excitation voltage from the SAS amplifier is applied through pins 8 and 9 of the card connector to the primary winding of reference voltage

transformer T601. Resistors R601 and R602 balance the circuit to ground, simulating the feedback variable resistors in the extensible link. The output of the secondary winding of the transformer is connected through limiting resistors R620 and R621 to a network consisting of diodes CR601, CR602, CR603 and CR604.

b. During the half the reference voltage cycle when diodes CR601 through CR604 are conductive, the junction of diodes CR603 and CR604 is at the same potential as the junction of diodes CR601 and CR602-signal ground potential. During the half-cycle when the diodes are nonconductive, the junction of diodes CR603 and CR604 is at signal voltage level. Thus the output of the phase inverter at the junction of isolating resistor R618 and R624 is interrupted at the power frequency rate and converted to a square wave. The phasing of the interruption and the polarity of the square wave are related to the characteristic of the correction signal in the SAS amplifier channel.

1-23. Preamplifier and Filter (fig. 1-2)

In the preamplifier and filter stages, the chopped output of the phase inverter is converted to a waveform approximating a sine wave of equal amplitude. The two-stage preamplifier has a gain of approximately 1000 which compensates for the attenuation of approximately 1000 in the filter (integrating network). The threshold level of input and output signals is 1 millivolt.

a. B+ (27 volts dc) from the dc distribution circuits of the test set is connected to the preamplifier through pin 16 of the card connector and the decoupling network consisting of resistor R653 and capacitor C617 and resistor R652 and capacitor C621. Operating voltage (approximately 23 volts dc) is connected to the emitter of transistor Q602 through resistor R632; base bias is furnished by resistor R633.

b. The square wave input signal is connected through isolation resistor R624 and dc-blocking capacitor C605 to the base of PNP transistor Q602. The amplified square wave is developed across collector load resistor R623 and coupled to the second stage through dc-blocking

capacitor C604. Capacitor C610 bypasses the signal around emitter resistor R632. Negative feedback for stability is provided through resistor R628.

c. Except for reference designations and the values of certain components which alter its gain, the second amplifier stage is identical with the first stage. Corresponding components perform corresponding functions.

d. The square wave output of the two-stage amplifier is coupled through dc-blocking capacitor C603 to an integrating network consisting of resistors R626, R629, and R634 and capacitors C606, C607, and C608. In the integrating network, the square wave is converted, first to a triangular wave, then to a sine wave.

1-24. Amplifier

(fig. 1-2)

In the three-stage amplifier as it is used in the SAS bench test set the sine wave (approximate) signal from the integrating network is amplified and coupled as a simulated link feedback (cancellation) signal to the SAS amplifier channel and to the simulator card meter rectifier stage. Amplifier stability is provided by one external and three internal feedback loops and the total gain of the 3-stage amplifier is approximately 1000.

a. B + (27 volts dc from the dc supply of the test set) is connected to the amplifier through decoupling networks consisting of resistor R653 and capacitor C617 and resistor R647 and capacitor C616. Operating voltage (approximately 23 volts dc) is connected to the emitter of first amplifier Q604 through resistor R639; base bias is furnished by resistor R638.

b. The sine wave input signal is connected through gain control resistor R635 and dc-blocking capacitor C611 to the base of PNP transistor Q604. The amplified output signal is developed across collector load resistor R641 and coupled to the second amplifier stage through dc-blocking capacitor C612. Capacitor C613 bypasses the signal around emitter resistor R639 and resistor R637 provides negative feedback for stability.

c. Except for the reference designations of its components, the second amplifier is identical with the

first and corresponding components perform corresponding functions.

d. Operating voltage (approximately 23 volts dc) is connected to the emitter of amplifier Q606 through resistor R651 and ac degeneration resistor R650; base bias is furnished by resistor R649. The sine wave output of the second amplifier is connected through dc-blocking capacitor C614 to the base of transistor Q606. The amplified output signal is developed across the primary winding of transformer T604, phase corrected by capacitor C619 and coupled through dc-blocking capacitor C618 to the meter rectifier stage and through pin 25 of the card connector and the test set receptacle to the feedback (cancellation voltage) circuit of the SAS amplifier. Capacitor C620 bypasses the signal around emitter resistor R651. Resistor R650 provides negative feedback in the third stage and resistor R636 completes the external feedback loop to the first stage, establishing gain and phase shift.

1-25. Axis Meter Rectifier

(fig. 1-2)

In the meter rectifier (phase-sensitive demodulator) stage, the simulated extensible-link feedback signal from the amplifier is converted to a positive or negative dc voltage. The polarity of this voltage is a function of the phase of the ac input signal. This stage functions as a meter rectifier when relay K601 is released (AXES METER READ switch S4 at CLOSED LOOP FEEDBACK V). When relay K601 is operated (AXES METER switch S4 at OPEN LOOP TOR MOT V), the meter rectifier is inoperative and the open loop output of the SAS amplifier channel is connected through contacts 5 and 2 and through meter multiplier R640 and contacts 1 and 6 of relay K601 to the AXIS meter.

NOTE

The dc output of the meter rectifier stage is taken across the center taps of reference voltage transformer T603 and signal transformer T602 and applied to the zero-center axis meter. To maintain consistency in the direction of meter indications

despite phasing differences in SAS amplifier channels, the connections to the yaw axis meter M2 are reversed. For simplicity in text, the stage is described with the center tap of reference voltage transformer T603 connected to the negative terminal of an axis meter and the center tap of signal transformer T602 connected to the positive terminal.

a. Twenty-six volts ac from transformer T501 (fig. 1-2) is connected through pin 19 of the card connector to the primary winding of reference voltage transformer T603. The output of the transformer, 5 volts centertapped to the negative side of the axis meter, is applied to a demodulator consisting of diodes CR609 through CR612 and signal transformer T602. On one half-cycle of reference voltage from transformer T603, diodes CR611 and CR612 conduct. On the alternate half-cycle, diodes CR609 and CR610 conduct. When a diode pair is conductive, the circuit is closed through the associated half of the signal transformer secondary to the positive side of the axis meter. In effect, the positive side of the axis meter is switched from one half to the other half of the secondary winding of signal transformer T602 at the power frequency rate. Without an ac signal in the primary winding of transformer T602, the output to the meter is theoretical zero, a series of self-canceling pulses of negligible amplitude which have no effect on the axis meter indication.

b. When a simulated feedback signal from the amplifier is applied to the primary winding of signal transformer T602, the voltage applied to the meter is the signal output of one half of the secondary winding during its positive or negative half-cycle and the signal output of the other half of the secondary during its corresponding half-cycle. The output of the signal transformer at the center tap is a series of positive or negative pulses, depending upon the phase of the simulated feedback signal. This positive or negative output voltage is applied through calibrating resistor R648 and contacts 8 and 6 of relay K601 to the positive side of the axis meter.

1-26. External Card Test Circuits

1-27. Demodulator-Modulator Card Test Circuit (fig. 1-5)

The demodulator-modulator card test circuit furnishes operating voltage, an input signal, and interstage resistive coupling which simulates a SAS amplifier shaping network and connects the output of the demodulator-modulator card through a gain control network and an amplifier to loading and metering circuits.

a. *Operating Voltage.* Twenty-six volts ac from the power supply of the test set is connected through pin 18 of DEM/MOD receptacle J70. This 26 volts ac is used as reference voltage on all types of demodulator-modulator cards. On demodulator-modulator cards which include a gyro signal amplifier, the 26 volts ac is also rectified on the card to furnish dc operating voltage for the amplifier stage.

b. *Input Signal.* Twenty-six volts ac from the power supply of the test set is also connected to the primary winding of stepdown test signal transformer T301 (on card A02V3064). The secondary winding is center tapped to ground and the opposite ends of the winding are connected to phase-reversing CARD TEST SIGNAL switch S6. Operating switch S6 to L or R connects the selected phase of the test signal through voltage divider R310 and R311 (on card A02V3064) and pin 15 of receptacle J67 to the junction of resistors R501 and R503 (on switch S7). The signal is then connected through resistors R501 and R503 to pins 8 and 3, respectively, of receptacle J70.

c. *Shaping Network Simulator.* In normal operation, the demodulator stage is coupled through an RC shaping network to the modulator stage (refer to the applicable SAS maintenance manual). Since the shaping network is not part of the card circuit, resistor R205 (on card A02V3060) is connected between pins 7 and 1 of receptacle J70 to couple the stages and simulate the impedance of the shaping network.

d. Output Signal Circuit. The output of the modulator stage from pin 16 of receptacle J70 is connected through a gain control network to a four-stage amplifier card 14E3049-19. The gain control network, consisting of capacitor C203 and resistors R206 and R207 (on card A03V3060), simulates the full-gain configuration of the gain control network in the SAS amplifier. From pin 18 of receptacle J66, the controlled output is applied to the input circuit of the four-stage amplifier card at pin 6 of receptacle J69. This amplifier card is identical with the amplifier card used in SAS amplifiers (para 1-28). The differential output of the amplifier card at pins 13, 15, and 17 of receptacle J69 is applied across torque motor simulator resistors R302 and R303 (on card A02V3064). Connections to function meter M1 are routed from pins 3 and 6 of receptacle J67 through the DEM OUTPUT positions of FUNCTION switch wafers S7A and S7B. Resistor R304 (on card A02V3064) is a meter multiplier.

1-28. Amplifier Card
(fig. 1-3)

On the amplifier card, the test signal output of the demodulator-modulator card under test is amplified, converted to a differential dc current in a phase-sensitive demodulator, and coupled through emitter followers to resistive loads which simulate the torque motor windings of an extensible link. The output of the emitter followers is also connected to function meter M1 to permit monitoring the amplitude and polarity of the differential current output.

a. First Ac Amplifier. The signal input path is completed through a phase-correcting gain-control network consisting of resistor R18 and capacitor C10. The amplified output signal is taken across the emitter and collector and coupled through interstage transformer T7 to the second ac amplifier. Operating voltage (approximately 23 volts dc) from pin 8 of the card connector is connected to the voltage-dividing and biasing network consisting of resistors R7, R8, and R10. Operating voltage is applied to the emitter of transistor Q1 through dc degeneration resistor R10 and ac degeneration resistor R9. The voltage-dividing network, consisting of resistors R7 and R8, halves the supply voltage and provides bias to the base of the transistor

through the secondary winding of transformer T6. The emitter-base bias differential of approximately 0.2 volt makes transistor Q1 conductive at all times. Capacitors C4 and C5 complete the signal input and signal output coupling circuits, respectively, to the emitter of ac amplifier Q1.

b. Second Ac Amplifier. The amplified signal from the secondary winding of interstage transformer T7 is applied across the emitter and base of PNP transistor Q2; the amplified output signal is taken across the emitter and collector and coupled through interstage transformer T8 to the demodulator. Operating voltage (27 volts dc) from the power supply of the test set is connected through pin 7 of the card connector to the voltage dividing and biasing network consisting of resistors R11, R12, and R14. Operating voltage is supplied to the emitter of transistor Q2 through dc degeneration resistor R14 and ac degeneration resistor R13. The voltage dividing network, consisting of resistors R11 and R12, halves the supply voltage and provides bias to the base of transistor Q2 through the secondary winding of transformer T7. The emitter-base differential of approximately 0.2 volt makes transistor Q2 conductive at all times. Despite the higher operating voltage, the gain of the second ac amplifier stage is approximately the same as that of the first. Capacitors C6 and C7 complete the signal input and signal output coupling circuits to the emitter of ac amplifier Q2.

c. Demodulator and Emitter-Followers. In the demodulator, a 400-cycle reference voltage (approximately 8 volt ac) from phase-shifting voltage-divider network C201, R312, R313 is applied to the center tap of the secondary winding of interstage transformer T8.

(1) During a no-signal condition, only the reference voltage is present in the secondary winding of transformer T8. The positive half-cycle of this reference voltage, taken from both ends of the winding, is rectified by diodes CR9 and CR10. The dc output of diode rectifier CR9 is filtered by capacitor C8 and applied to load resistor R15 which is connected across the base and collector of transistor Q3. The dc output

of diode rectifier CR10 is filtered by capacitor C9 and applied to load resistor R16 which is connected across the base and collector of transistor Q4. Twenty-seven volts dc from the power supply of the test set is connected through current limiting resistor R17 to the junction of torque motor simulator resistors R302 and R303. The opposite ends of these resistors are connected to the emitters of transistors Q3 and Q4. With only the rectified reference voltage on the bases, equal currents flow through the emitters and the differential indicated by meter M1 is zero.

(2) When a test signal is present in the primary of interstage transformer T8, the signal will, depending on its phase, add to the positive half-cycle of reference voltage at diode CR9 or CR10 and subtract from the positive half-cycle at the other diode. With unequal dc potentials applied to the bases, unequal currents will flow through the emitters of transistors Q3 and Q4 and through resistors R303 and R302. The direction and amplitude of the differential is indicated on function meter M1.

1-29. Amplifier Card Test Circuit

(fig. 1-5)

The amplifier card test circuit furnishes operating voltage and an input test signal to the card under test and connects the output of the card to the loading and metering circuits.

a. Operating Voltage. Twenty-six volts ac from the power supply of the test set is connected through an RC

network consisting of resistors R313, R312, and capacitor C201 to pin 19 of AMPLIFIER receptacle J71. This circuit also furnishes ac reference voltage for the amplifier card of the demodulator-modulator card test circuit (para 1-28). Twenty-seven volts dc from the power supply of the test set is connected directly to pin 7 and through a decoupling network consisting of resistor R203 and capacitor C202 to pin 8 of AMPLIFIER receptacle J71; pins 1 and 12 provide the ground returns. These are the dc operating voltages for the amplifier stages.

b. Input Signal. Twenty-six volts ac from the power supply of the test set is also connected to the primary winding of stepdown test signal transformer T301 (on card A02V3064). The secondary winding is center tapped to ground and the opposite ends of the winding are connected to phase-reversing CARD TEST SIGNAL switch S6. Operating the switch to L or R connects the selected phase of the test signal through a voltage divider network R308 and R309 (on card A02V3064) to the input of the amplifier through pin 6 of receptacle J71.

Figure 1-2. Actuator-simulator card schematic diagram.

(Located in back of manual.)

(Next printed page is 13)

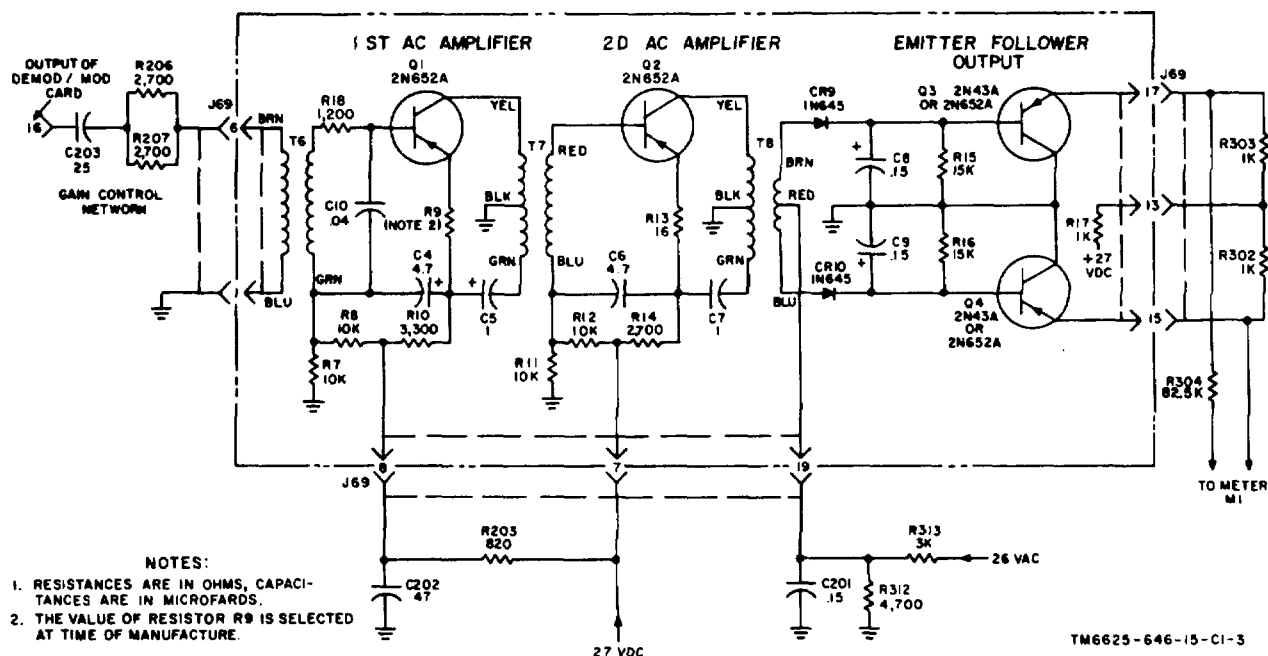

Figure 1-3. Amplifier card, schematic diagram.

c. *Output Signal.* The output signal of the amplifier card is routed through pins 13, 15, and 17 of receptacle J71 and is applied across torque motor simulator load resistors R306 and R307 (on card A02V3064). Connections to the function meter M1 are routed from pins 7 and 10 of receptacle J67 through the AMPL OUP T position of FUNCTION switch wafers S7A and S7B. Resistor R307 (on card A02V3064) is a meter multiplier.

1-30. Function Meter Circuits

1-31. Dc Metering Circuits

(fig. 1-4)

During dc metering functions, all connections to FUNCTION meter M1 are made through FUNCTION switch wafers S7A and S7B and a selected meter multiplier resistor. For each position of switch S7 the meter multiplier resistor has a value which results in a meter indication within the red or green sector of the scale.

a. When FUNCTION switch S7 is at DC PWR, the output of the 27-volt dc supply of the test set is connected to meter M1 through multiplier resistor R201.

b. When FUNCTION switch S7 is at PEDAL POT. EXCITATION, the positive and negative 18-volt excitation from the SAS amplifier (for the pedal position variable resistor) is connected to meter M1 through multiplier resistor R301.

c. When FUNCTION switch S7 is at INTLK the 28-volt dc interlock voltage from the SAS amplifier (for the gain control relay in the other SAS amplifier of a dual system) is connected to meter M1 through multiplier resistor R202.

d. When FUNCTION switch S7 is at DEM OUP T, the differential output of amplifier card P69 in the test set, applied across load resistors R302 and R303, is connected to meter M1 through multiplier resistor R304.

e. When FUNCTION switch S7 is at AMPL OUP T, the differential output of the amplifier card (not shown) in AMPLIFIER receptacle J71, applied across load resistors R306 and R307, is connected to meter M1

through multiplier resistor R305.

f. When FUNCTION switch S7 is at PEDAL POT. OUP, the simulated feedback being fed from the moving contact of PEDAL POT resistor R502 to the yaw channel of the SAS amplifier is connected to meter M1 through multiplier resistor R401.

1-32. Ac Metering Circuits

(fig. 1-4)

During ac metering functions, the voltage to be measured is connected through a calibrating resistor and FUNCTION switch wafers S7C and S7D to test voltage input transformer T402 of the function meter rectifier (para 1-33). The dc output of the meter rectifier is applied across a meter shunt and through FUNCTION switch wafers S7A and S7B to FUNCTION meter M1. For each position of switch S7, the calibrating resistor has a value which, together with the value of the meter shunt, results in the meter indication within the red or green sector of the scale.

a. When FUNCTION switch S7 is at AC PWR, the 26-volt output of the secondary winding of test set power transformer T501 is connected to input transformer T402 through calibrating resistor R406.

b. When FUNCTION switch S7 is at YAW, ROLL, or PITCH FEEDBACK POT. EXCITATION, the primary excitation voltage (from the SAS amplifier), normally applied to the primary feedback variable resistor in the corresponding extensible link, is connected to input transformer T402 through switch S5 and calibrating resistor R402, R403, or R404, respectively.

c. When FUNCTION switch S7 is at SEC. FEEDBACK POT EXCITATION, the secondary excitation voltage (from the SAS amplifier), normally applied to the secondary feedback variable resistor in the extensible links is connected to input transformer T402 through calibrating resistor R405.

1-33. Function Meter Rectifier

(fig. 1-4)

In the meter rectifier (phase-sensitive demodulator), the ac voltage to be measured is converted to a positive or negative dc voltage. The polarity of the dc output voltage is a function of the phase of the ac input voltage.

a. Twenty-six volt ac from power transformer T501 is connected to the primary of reference voltage transformer T401. The output of transformer T401, is 5 volts centertapped to the negative side of FUNCTION meter M1. This output is applied to a demodulator consisting of diodes CR401 through CR404 and test voltage input transformer T402. On one half-cycle of reference voltage, diodes CR401 and CR402 conduct. On the alternate half-cycle, diodes CR403 and CR404 conduct. When a diode pair is conductive, the circuit is closed through the associated half of the input transformer secondary to the positive side of meter M1. In effect, the positive side of meter M1 is switched from one half to the other half of the secondary of input transformer T402 at the power frequency rate. Without an ac voltage in the primary winding of transformer T402, the output to meter M1 is theoretical zero, a series of self-canceling pulses of negligible amplitude which have no effect on the meter indication.

b. When ac test voltage is applied to the primary of transformer T402, the voltage applied to meter M1 is the output of one half of the secondary winding during its positive or negative half-cycle and the output of the other half of the secondary during its corresponding half-cycle. The output of transformer T402 at the center tap is a series of positive or negative pulses, depending upon the phase of the ac voltage being measured. This dc output voltage is applied across meter shunt resistor R407 and through the ac test positions of FUNCTION switch S7 to the positive terminal of FUNCTION meter M1.

1-34. Miscellaneous Test Circuits

1-35. ASE Mode

These circuits not applicable to the CH-47 SAS amplifier.

1-36. Half-Gain Mode

(fig. 1-5)

During normal operation, each SAS amplifier operates at half gain. During bench testing,

the SAS amplifier normally operates at full gain. To check its half-gain operation, the SAS amplifier gain-control relay must be energized. Gain-control relay operation is controlled by HALF GAIN switch S3. It connects 32 volts dc from the test set power supply through J60 pin F to the control side of the relay winding. The other side of the relay winding is connected to ground through J60 pin G. FULL GAIN indicator DS2 monitors gain control relay operation. When operated, the gain control relay contacts open a ground connection at J60 pin E and indicator DS2 goes out.

1-37. Power Supplies

1-38. Ac Power Circuit

(fig. 1-5)

The 115-volt single-phase 400-cycle supply voltage is supplied to the test set through receptacle J62 pin C. Pin A provides the ground return. This voltage is routed through 115V 400-POWER circuit breaker switch S1 to power indicator DS1 and to the primary winding of transformer T501. The 26-volt ac output from the secondary of T501 is distributed to pins 19 of receptacles J63, J64, and J65, to pin 14 of receptacle J66, to pin 18 of receptacle J70, to pin 18 of receptacle J67, and to pin 12 of receptacle J68. Also, 115-volt ac operating voltage is connected through contacts 8 and 4 of adapter switch wafer S5A (front) to SAS amplifier receptacle J60 pin i.

Figure 1-4. Function meter circuit, simplified schematic.

(Located in back of manual.)

1-39. Dc Power Circuit

Twenty-six volts ac from the test set ac power supply is connected to receptacle J66 pin 14. This voltage is rectified and filtered to 32 volts dc by the network consisting of diodes CR201 and CR202, resistor R204, and capacitor C201. It is further regulated to 27 volts dc by Zener diode CR501. The regulated dc is distributed to pins 2 and 5 of receptacle J66, to pin 7 of receptacle J71, to pin 7 of receptacle J69, to pins 16 of receptacles J63, J64, and J65 through pins 5 and 6 of AXES METERS READ switch S4, and to pin A of SAS amplifier receptacle J60. The unregulated 32 volts dc is

distributed to pins 22 of receptacles J63, J64, and J65 through contacts 1 and 2 of AXES METERS READ switch S4, to receptacle J60 pins F and E, through HALF GAIN switch S3 and FULL GAIN indicator light DS2.

1-40. Pneumatic System

(fig. 1-6)

1-41. Pitot and static pressure for the air-speed sensor and differential pressure for the sideslip sensor, required for testing the SAS amplifier yaw channel is simulated by the test set pneumatic system. An electrically driven air pump supplies the air pressure. The pump is energized when the PUMP switch S2 is operated to its on (UP) position.

a. Two front panel indicators, AIRSPEED and DIFF. PRESSURE, monitor the simulated airspeed and differential pressure supplied to the sensors. Two front panel regulator valves, AIRSPEED REG and DIFF. PRESS. REG. enable the operator to control the air pressure.

b. With the AIRSPEED REG valve turned slowly clockwise (from its top center position) positive pressure is applied to the pitot (P) fitting on the test set and to the P connection of the AIRSPEED indicator. At the same time, static pressure (vacuum) is applied to the static (S) fitting on the test set and to the S connection of the AIRSPEED indicator. Simulated airspeed is indicated in knots.

**Figure 1-5. Test set, schematic diagram.
(Located in back of manual.)**

c. With the DIFF. PRESS. REG. valve turned slowly clockwise (from its top center position) air pressure is applied to the R fitting on the test set and to the DIFF. PRESSURE indicator. The indicator pointer will move to the right (R) and indicate the simulated differential pressure.

d. With the DIFF. PRESS. REG. valve turned slowly counterclockwise, air pressure is applied to the L fitting on the test set and to the DIFF. PRESSURE indicator. The indicator pointer will move to the left (L) and indicate the simulated differential pressure.

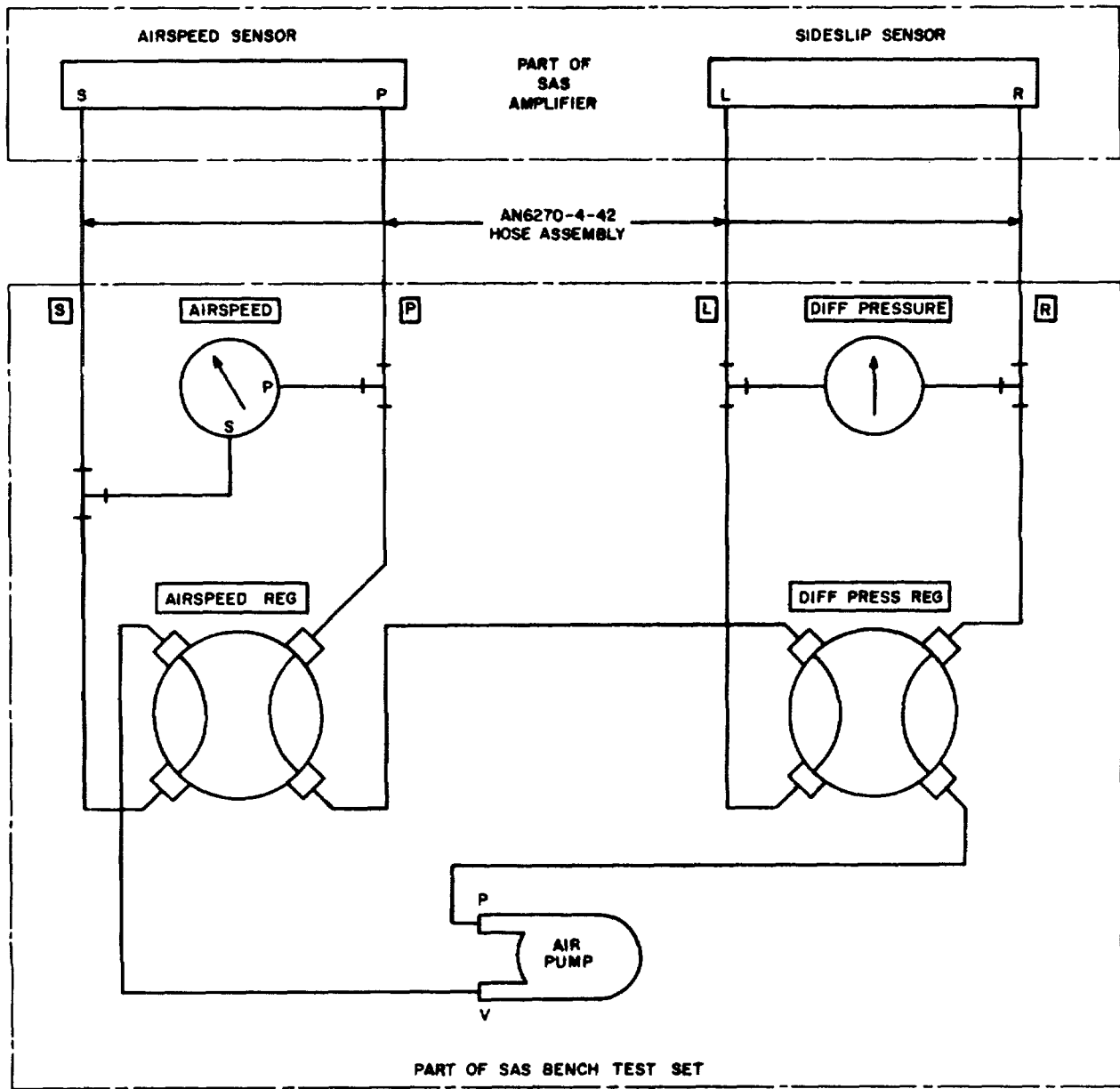

TM6625-646-15-C1-6

Figure 1-6. Pneumatic system, schematic diagram.

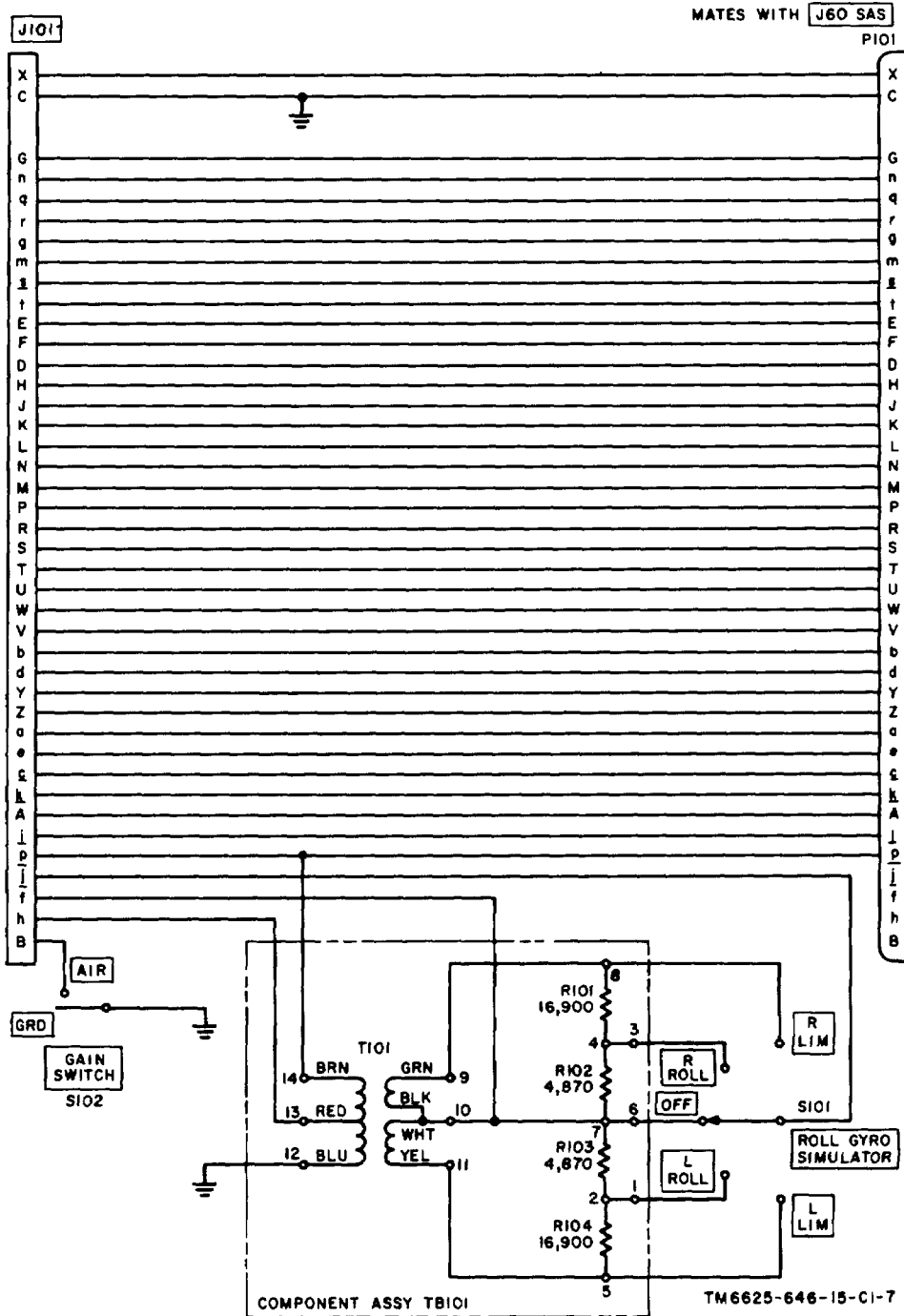

Figure 1-7. Adapter, schematic diagram.
(Next printed page is 23)

SECTION II SPECIAL SERVICE TOOLS

2-1. SPECIAL SERVICE TOOLS

2-2. There are no special service tools or fixtures required for the maintenance of the SAS Bench Test Set. However, in order to test a SAS amplifier, Simulator, Aircraft Displacement AN/ASM-120 (rate

table) with an operating range of 90 to 1080 degrees per minute is required. Refer to TM 11-6625-613-12 for operating procedures for the AN/ASM-120.

Change 4 23/(24 blank)

SECTION III PREPARATION FOR USE, STORAGE OR SHIPMENT

3-1. Unpacking and Inspection

(fig. 3-1)

No special unpacking procedures are required to remove the test set from its shipping container. After unpacking, inspect the test set as follows:

CAUTION

The SAS bench test set is a delicate instrument and must be handled carefully to prevent damage which might render the set inoperative.

- a. Open the air pressure relief valve in the cover to equalize inside and outside air pressure.
- b. Unlatch and remove the cover; refer to table 1-1 and check the accessories stowed in the cover for missing items.
- c. Release the hinged latch assemblies on the front panel and remove the operating instructions retainer assembly. Visually inspect the front panel for damaged or loose components (table 5-1).
- d. Remove the 14 screws and washers from the front panel and remove the panel-chassis assembly from the case; visually inspect the interior for damaged or loose components (table 5-1).
- e. If any damage is found, refer to the troubleshooting procedures in section VI. If no discrepancies exist, replace the panel-chassis assembly in the case and secure it with the screws and washers.
- f. If the test set is not used immediately, replace the cover and close the air pressure relief valve.

3-2. Preparation for Use

(fig. 3-1)

The test set is a portable unit and no special installation is required. Power requirements are 115 volts 400 cycles single-phase ac for the test circuits and 115 volts, 60 cycles single-phase ac to operate the air pump. All voltages are $\pm 5\%$. Prepare the test set for use as follows:

- a. Open the air pressure relief valve in the cover to equalize inside and outside air pressures.
- b. Unlatch and remove the cover from the test set; release the turnlock fasteners and open the metal door to remove the cable, hose, and bag assemblies from the cover. In the -8 test set, remove the adapter from the cover.
- c. If the test set is to be secured to the back panel of a workbench, loosen the three knurled nuts inside the cover and push the panel-mounting studs out of their retracted position; latch the cover to the bottom of the base of the test set and secure the test set to the panel.

3-3. Preparation for Storage

No special preparations are required before storing the test set. Refer to table 1-1 to be certain that the test is complete before stowing the accessories in the cover, closing the cover, and storing the test set. The SAS bench test set does not require special storage facilities. The unit should be stored in a clean, dry area.

3-4. Preparation for Shipment

To prepare the test set for shipment, proceed as follows:

- a. Remove the three cable assemblies from their respective receptacles on the front panel of the test set. Store the cable assemblies in the cover of the test set case as shown in figure 1-1.

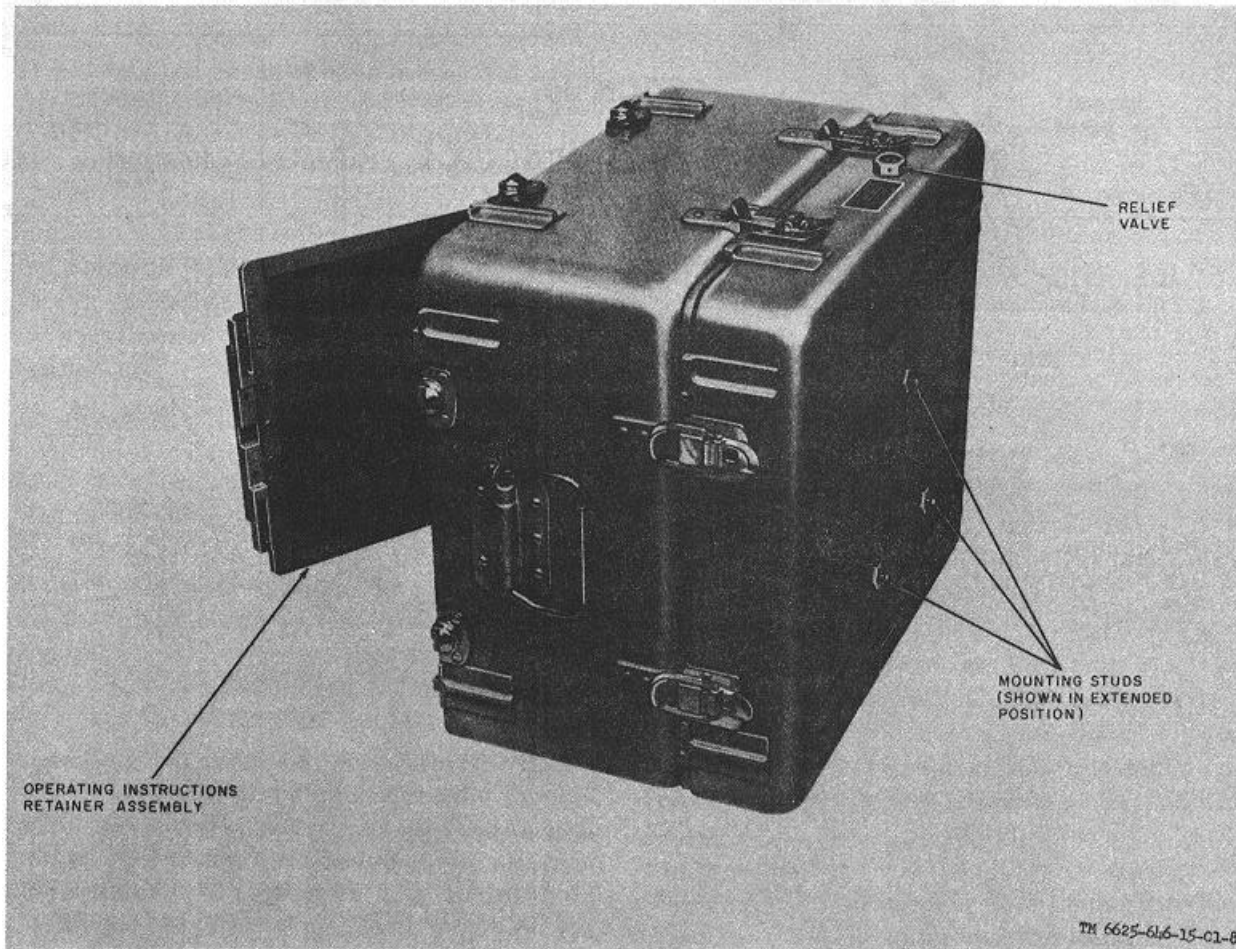

Figure 3-1. Test set with mounting studs extended.

b. Disconnect the four hose assemblies from the front panel of the test set. Store the hose assemblies in the test set cover (fig. 1-1).

c. Check the 14 screws that secure chassis to the case. Tighten the screws as required.

d. Check that special tools are stowed in the bag. Refer to table 1-1.

e. Store the adapter assembly in the cover of the - 8 test set.

f. Place the cover on the case. Secure the eight latches.

g. Install the test set in a shipping container. The equipment is now ready for shipment.

SECTION IV OPERATING INSTRUCTIONS

4-1. General

4-2. This section contains operating instructions for the test set. Functions and descriptions of the controls, indicators, and receptacles are given in tables 4-1, 4-2, and 4-3. Numbers in parentheses refer to items on figure 4-1. Reference designations are given to relate these components to the schematic diagrams, figures 1-5 and 1-7. Figure 4-1 illustrates the front panel of the test set. Aircraft Displacement Simulator AN/ASM-120 or equivalent, having an operating range of 1.5° to 18° per second is required for yaw, roll, and pitch channel tests on SAS amplifiers. A multimeter, TS-352/U or equivalent, and a capacitance, inductance, resistance bridge, AN/URM-90 or equivalent, are also required for calibration card tests.

4-3. SAS Component Tests

4-4. Preliminary Procedures

4-5. (fig. 4-2). Test a SAS amplifier or printed-wiring circuit board as follows:

- a. Release the turnlock fasteners and open the hinged door in the test set cover.
- b. Set the POWER and PUMP switches to off (down) positions.
- c. Remove the test cables and hose assemblies from the test set cover. Remove the adapter assembly from the -8 test set.
- d. Connect power cable A02VS309-3 between the 115V 400 ~ test set receptacle and a 115-volt 400-cycle ac source.
- e. Connect test cable A02VS309-1 between the test set J60 SAS receptacle and the SAS amplifier receptacle. If SAS amplifier 114E3030-49 is being

tested, connect adapter 114V3058-1 between the test set J60 SAS receptacle and test cable A02VS309-1.

4-6. SAS Amplifier Testing Procedures

4-7. To test a SAS amplifier, perform the preliminary procedures in paragraph 4-4. Then proceed as directed in the paragraphs that follow. The results of some SAS amplifier tests are not included in this manual since the information is not the same for all models and certain values are subject to change. For this information, refer to TM 11-1680-201-35. Some results not included are the following:

- a. Test voltages not directly related to power voltage levels.
- b. Amplifier positioning and channel rate of turn tests which require the use of the rate table.
- c. Channel output during open and closed loop testing.
- d. Test airspeed and test sideslip pressures.
- e. Yaw channel output during airspeed and sideslip channel tests.

4-8. Channel Tests Using a Rate Table

Check channel response to rate gyro signals as follows:

- a. Check that the ASE MODE switch is at OFF. Check that the FUNCTION switch is at DC. Check that the AXES METERS READ switch is at CLOSED LOOP. Check that the PEDAL POT variable resistor is in the center of its operating range (straight up).
- b. Position the SAS amplifier on the rate table so it turns about the sensitive axis of the channel being tested.

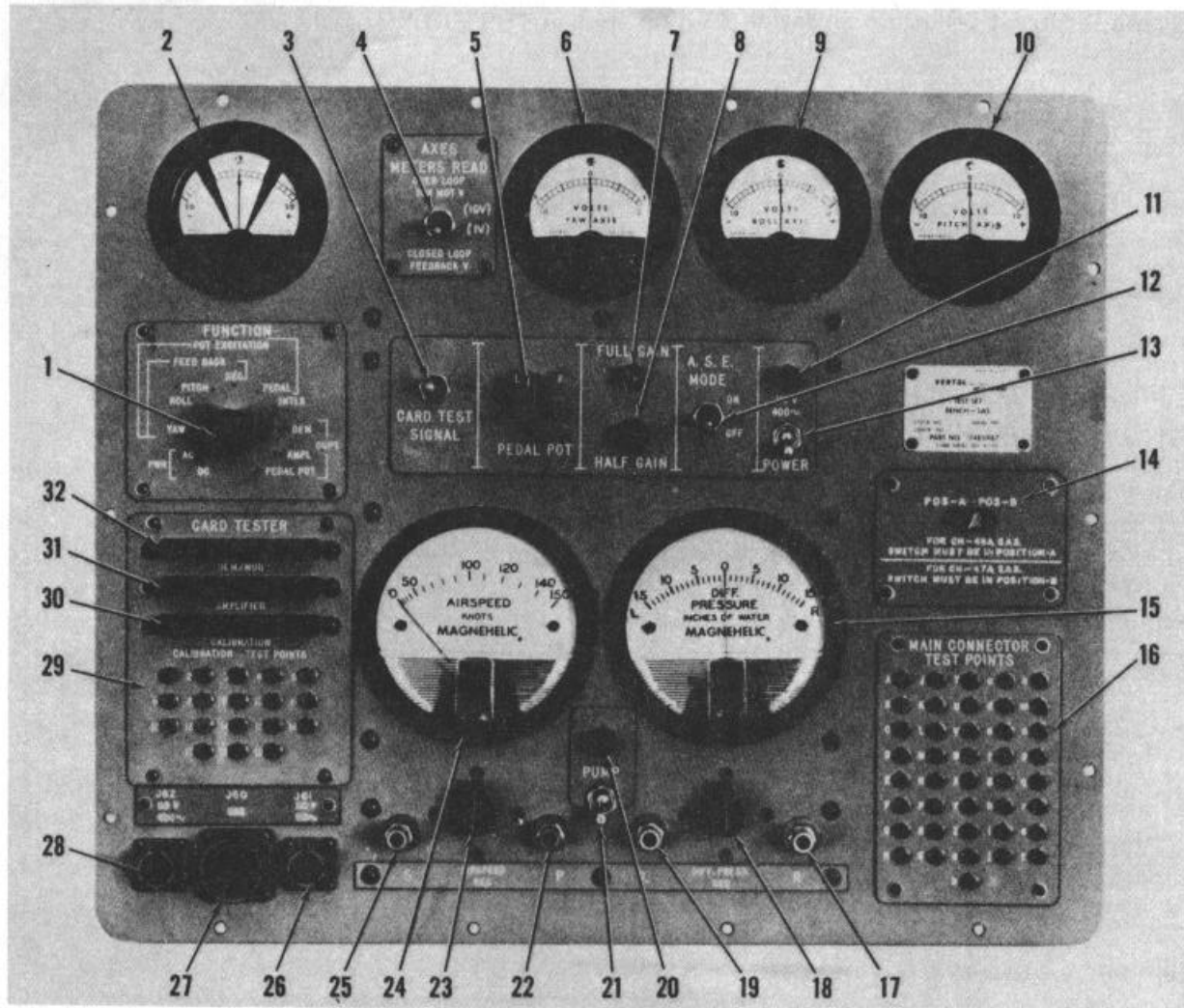

- | | |
|--------------------------------|--------------------------------------|
| 1. FUNCTION SWITCH | 17. R AIR CONNECTION |
| 2. FUNCTION METER | 18. DIFF PRESS. REG VALVE |
| 3. CARD TEST SIGNAL SWITCH | 19. L AIR CONNECTION |
| 4. AXES METERS READ SWITCH | 20. PUMP ON INDICATOR LIGHT |
| 5. PEDAL POT CONTROL | 21. PUMP SWITCH |
| 6. YAW AXIS METER | 22. P AIR CONNECTION |
| 7. FULL-GAIN INDICATOR LIGHT | 23. AIRSPEED REG VALVE |
| 8. HALF-GAIN SWITCH | 24. AIRSPEED INDICATOR |
| 9. ROLL AXIS METER | 25. S AIR CONNECTION |
| 10. PITCH AXIS METER | 26. 115V 60/0 POWER RECEPTACLE |
| 11. POWER ON INDICATOR LIGHT | 27. SAS AMPLIFIER RECEPTACLE |
| 12. ASE MODE SWITCH | 28. 115V 400/0 POWER RECEPTACLE |
| 13. POWER SWITCH | 29. CALIBRATION TEST POINTS |
| 14. ADAPTER SWITCH | 30. CALIBRATION CARD TEST RECEPTACLE |
| 15. DIFF PRESSURE INDICATOR | 31. AMPLIFIER CARD TEST RECEPTACLE |
| 16. MAIN CONNECTOR TEST POINTS | 32. DEM/ MOD CARD TEST RECEPTACLE |

TM 6625-646-15-C1-9

Figure 4-1. Test set, front panel.

c. Set the 115V 400 ~ POWER switch to on (up) position. Check that the FULL GAIN indicator lamp comes on. Check that the FUNCTION meter indicates in the green.

NOTE
The AXIS meters will indicate off-scale and slowly return to center-scale. This is normal and does not indicate equipment malfunction.

Table 4-1. Controls

Control	Function
FUNCTION Switch S7 (1).....	<p>Four-pole, 11-position rotary switch; selects circuit to be tested and connects this circuit to the FUNCTION meter to measure voltages. The color of the dot at each switch position indicates the sector of the meter scale where voltage should be indicated. Where two dots appear, the position of the CARD TEST SIGNAL switch determines the sector where voltage should be indicated. The function of each switch position is as follows:</p> <p>DC-measures the level of the dc operating voltage to the SAS amplifier.</p> <p>AC-measures the level of ac operating voltage to the SAS amplifier.</p> <p>YAW FEED BACK POT. EXCITATION-measures the level of the excitation voltage for the primary feedback variable resistor in the yaw extensible link.</p> <p>ROLL FEED BACK POT. EXCITATION-measures the level of the excitation voltage for the primary feedback variable resistor in the roll extensible link.</p> <p>PITCH FEED BACK POT. EXCITATION-measures the level of the excitation voltage for the primary feedback variable resistor on the pitch extensible link.</p> <p>SEC FEED BACK POT. EXCITATION-measures the level of the excitation voltage for the secondary variable resistors on the pitch, roll, and yaw extensible links.</p> <p>PEDAL POT. EXCITATION measures the level of excitation voltage to the pedal position variable resistor.</p> <p>INTLK-measures the level of the dc interlock voltage to the other SAS amplifier.</p> <p>DEM OUPT-measures the output of the demodulator-modulator card when the card is plugged into the DEM/MOD CARD TESTER receptacle of the test set and the CARD TEST SIGNAL switch is operated.</p> <p>AMPL OUPT-measures the output of the amplifier card when the card is plugged into the AMPLIFIER CARD TESTER receptacle of the test set and the CARD TEST SIGNAL switch is operated.</p> <p>PEDAL POT. OUPT-measures the simulated feedback output of the PEDAL POT variable resistor.</p>
CARD TEST SIGNAL Switch S6 (3)	<p>Single-pole double-throw toggle switch with two momentary positions; connects the test signal to the input of the demodulator-modulator or amplifier card that is connected to the CARD TESTER receptacle of the test set. Color of dot indicates the sector of the FUNCTION meter where voltage should be indicated.</p>
PEDAL POT Variable Resistor R502 (5)	<p>No function on CH-47 SAS amplifiers.</p>
HALF GAIN Switch S3 (8)	<p>Normally open push-button switch; when depressed, it energizes the gain control relay in the SAS amplifier causing the amplifier to operate at half gain.</p>
ASE MODE Switch S8 (12) .	<p>No function on CH-47 SAS amplifiers.</p>
115V 400~ POWER Switch S1 (13).....	<p>Three-ampere circuit breaker switch; connects and protects the 115-volt 400-cycle ac circuit to the test set.</p>

Control	Function
Adapter Switch S6 (not readily accessible) (14).	Two-position 10-pole rotary switch. Position A adapts the test set circuits for H-46 or 107 SAS amplifiers. Position B adapts the test set circuits for CH-47 SAS amplifiers. This switch is factory preset at B.
PUMP Switch S2 (21).....	Three-ampere circuit breaker switch; connects and protects the 115-volt 60-cycle ac circuit to the pump motor.
AXES METERS READ Switch S4 (4).	Double-pole toggle switch; controls relays on the actuator simulator cards which connect the PITCH, ROLL, and YAW AXIS meters to measure the SAS amplifier channel output to the extensible link torque motor (solenoid) at OPEN LOOP and the simulated link feedback voltage at CLOSED LOOP.
AIRSPEED REG Valve (23)	Air valve. Controls the amount of air pressure to the SAS amplifier airspeed sensor.
DIFF PRESS. REG Valve (18)	Air valve. Controls the amount and direction of air pressure to the SAS amplifier sideslip sensor.
ROLL GYRO SIMULATOR Switch S101 on adapter (114E5987-8 only).	Single-pole, 5-position rotary switch. Applied simulated roll signals to SAS amplifier 114E3030-49. The function of each switch position is as follows: OFF-input to roll signal demodulator is short circuited. R ROLL-applies 3° right roll signal to SAS amplifier. R LIM-applies maximum right roll signal to SAS amplifier. L ROLL-applies 3° left roll to SAS amplifier. L LIM-applies maximum left roll signal to SAS amplifier.
GAIN SWITCH S101 on adapter (114E5987-8 only).	Spst toggle switch. Controls pitch axis gain, simulating ground/air operation when switch is set to GRD or AIR position respectively.

Table 4-2. Indicators

Indicator	Function
FUNCTION Meter M1 (2).....	Zero-center voltmeter, calibrated -20 to +20, with a red sector between -8 and -12 and a green sector between +8 and +12; indicates voltages at the circuit point selected by the FUNCTION switch.
YAW AXIS Meter M2 (6)	Zero-center voltmeter, calibrated -10 to +10 and -1 to +1; indicates output of yaw channel or simulated extensible link feedback (cancellation) voltage.
ROLL AXIS Meter M3 (9).....	Zero-center voltmeter, calibrated -10 to +10 and -1 to +1; indicates output of roll channel or simulated extensible link feedback (cancellation) voltage.
PITCH AXIS Meter M4 (10)	Zero-center voltmeter, calibrated -10 to +10 and -1 to +1; indicates output of pitch channel or simulated extensible link feedback (cancellation) voltage.
FULL GAIN Indicator Lamp DS2 (7)	Indicator lamp; goes out when the SAS amplifier gain control relay operates.
POWER Indicator DS1 (11).....	Indicator lamp; lights when 400-cycle power is applied to the test set.
PUMP INDICATOR DS3 (20)	Indicator lamp; lights when 60-cycle power is applied to the pump motor.
AIRSPEED INDICATOR (24).....	Air pressure indicator; calibrated 0 to 150 knots. Indicates the ram air pressure applied to the pitot connection of the SAS amplifier.
DIFF. PRESSURE Indicator (15)	Zero-center air pressure indicator; calibrated L15 to R15; indicates the relative amount and direction of differential pressure connected to the L and R sideslip connections of the SAS amplifier.

d. Turn the FUNCTION switch to AC PWR. Observe that the function meter indicates in the green sector.

e. Operate the rate table clockwise at the prescribed rate. Observe the channel feedback (cancellation) voltage on the associated AXIS meter.

NOTE

When testing the pitch channel in SAS amplifier 114E3030-49, set the adapter GAIN SWITCH to GRD during rate table operation. Observe the effect on the PITCH AXIS meter indication. Set the switch to AIR after observing the meter indication.

f. Operate the rate table counterclockwise at the prescribed rate. Observe the channel feedback voltage on the associated AXIS meter.

g. Set the AXES METERS READ switch to OPEN LOOP. Repeat e and f above. Observe the channel output voltages on the AXIS meters.

h. Set the AXES METERS READ switch to CLOSED LOOP.

i. To check the SAS amplifier half-gain function, press and hold the HALF-GAIN switch. Repeat e through g above. Observe that the FULL GAIN indicator goes out. Observe that the channel AXIS meter indication is reduced to the prescribed half-gain indication. Release the switch.

j. When testing the roll channel in SAS amplifier 114E3030-49, perform the following additional tests:

(1) Turn the adapter ROLL GYRO SIMULATOR switch to R ROLL.

(2) Check the roll channel balance. Refer to TM 11-1680-201-35.

(3) Press and release the HALF-GAIN switch. Observe the ROLL AXIS meter indication at each switch position.

(4) Turn the ROLL GYRO SIMULATOR switch to R LIM. Observe the ROLL AXIS meter indication.

(5) Turn the ROLL GYRO SIMULATOR switch to L ROLL. Repeat (2) and (3) above.

(6) Turn the ROLL GYRO SIMULATOR switch to L LIM. Observe the ROLL AXIS meter indication.

(7) Turn the ROLL GYRO SIMULATOR switch to OFF.

k. If no further tests are to be performed, stop the test set (para 4-20).

4-9. Airspeed and Sideslip Tests

Test the SAS amplifier airspeed and sideslip circuits as follows:

a. Set the AXES METERS READ switch to OPEN

Table 4-3. Receptacles

Receptacles	Function
115V 400~J62 (28)	<i>Ac power receptacle.</i> Connects 115-volt 400-cycle ac to test set circuits.
SAS J60 (27)	<i>Test receptacle.</i> Connects test set circuits to SAS amplifier.
115V 60~J61 (26)	<i>Ac power receptacle.</i> Connects 115-volt 60-cycle ac to the air pump.
R Air (17)	<i>Airhose fitting.</i> Connects sideslip pressure to the SAS amplifier R fitting.
L Air (19)	<i>Airhose fitting.</i> Connects sideslip pressure to the SAS amplifier L fitting.
P Air (22)	<i>Airhose fitting.</i> Connects pitot air pressure to the SAS amplifier P fitting.
S Air (25)	<i>Airhose fitting.</i> Connects static air to the SAS amplifier S fitting.
CARD TESTER (30, 31, and 32)	<i>DEM/MOD J70 (32)-Test receptacle for demodulator-modulator cards.</i> Connects to the test set circuits. <i>AMPLIFIER J71 (31)-Test.</i> receptacle for amplifier cards. Connects to the test set circuits. <i>CALIBRATION J72 (30)-Test receptacle for calibration cards.</i> Connects to the CALIBRATION TEST POINTS (29)-J42 through J59.
MAIN CONNECTOR TEST POINTS (16)-J1 through J41.	<i>Test jacks.</i> Connected to the corresponding pins of the SAS amplifier receptacle.

LOOP. Check that the ASE MODE switch is at OFF. Check that the PEDAL POT variable resistor is in the center of its operating range (straight up).

b. Connect the test set S, P, L, and R connections to the corresponding SAS amplifier connections. Use the hose assemblies and quick-disconnect couplings furnished with the test set. Connect power cable A02VS309-2 between the test set 115V 60~ and a 115-volt 60-cycle ac source.

c. Set the PUMP switch to on (up) position.

d. Adjust the DIFF PRESS REG valve until the required direction and magnitude of simulated sideslip is indicated on the SIDESLIP indicator.

e. Observe the output of the sideslip circuit on the YAW AXIS meter.

f. Adjust the AIRSPEED valve until the test airspeed is indicated on the AIRSPEED indicator.

g. Observe that the YAW AXIS meter indication is reduced as required by operation of the airspeed circuits.

h. Set the PUMP switch to off (down) position. Disconnect the hose assemblies from the S, P, L, and R connections. Stow the hose assemblies in the test set cover.

i. If no further tests are to be performed, stop the test set (para 4-20).

4-10. ASE Mode Tests

Not applicable to CH-47 SAS amplifiers.

4-11. Excitation Voltage Tests

To check the excitation voltage levels for the link feedback component, turn the FUNCTION switch to each POT EXCITATION position. Observe that the FUNCTION meter indicates in the green at each position.

4-12. Interlock Voltage Test

To measure the SAS amplifier half-gain interlock voltage, turn the FUNCTION switch to INTLTK. Observe that the FUNCTION meter indicates in the green.

4-13. Pedal Position Variable Resistor Feedback Voltage Test

Not applicable to CH-47 SAS amplifiers.

4-14. Internal Test Circuits

To check the SAS amplifier test circuits, proceed as follows:

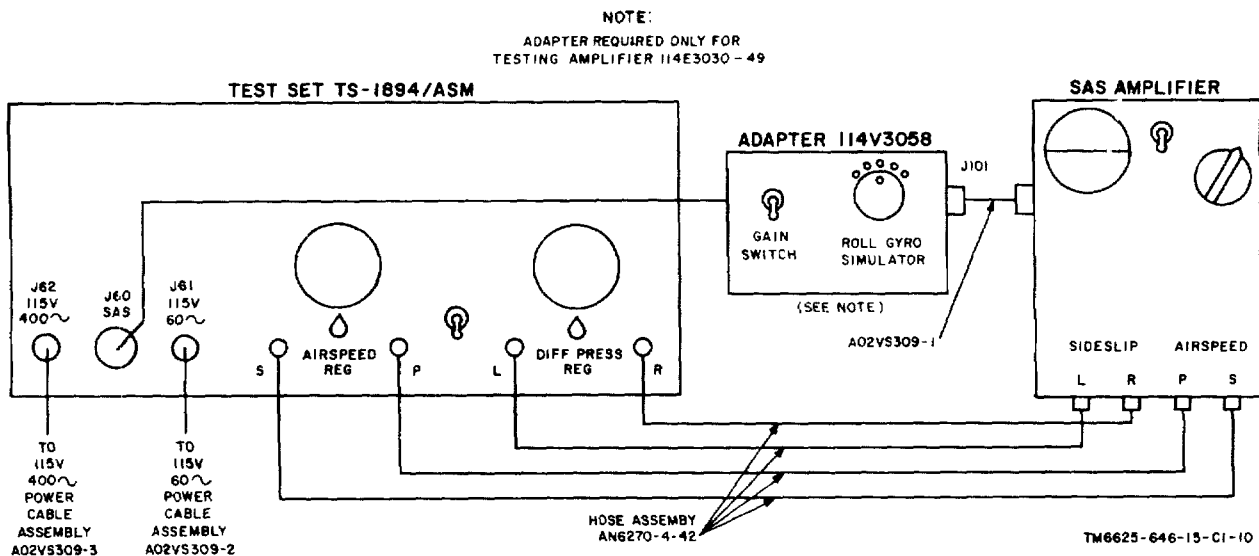

Figure 4-2. Test setup.

a. Turn the SAS amplifier selector switch to DC, then to AC. Observe the SAS amplifier meter for the required indication.

b. Set the AXES METERS READ switch to CLOSED LOOP.

c. Turn the SAS amplifier selector switch, in turn, to PITCH, ROLL, S/SLIP, and YAW. At each switch position, operate the L-R switch to each position. Observe the SAS amplifier meter for the required indication.

4-15. Printed-Wiring Circuit Board (Card) Tests

4-16. To test a SAS amplifier card, perform the preliminary procedures (para 4-4). Then proceed as directed below.

4-17. Demodulator-Modulator Card

Test a demodulator-modulator card as follows:

a. Plug the card into the DEM/MOD CARD TESTER receptacle, component-side down. Turn the FUNCTION switch to DEM OUP, Set the 115V 400~POWER switch to on (up) position.

b. Adjust variable resistor R76 on the card until the FUNCTION meter indicates 0.

c. Set the CARD TEST SIGNAL switch to L. Observe the FUNCTION meter for the required indication.

d. Set the CARD TEST SIGNAL switch to R. Observe the FUNCTION meter for the required indication.

e. If no further tests are to be performed, stop the test set (para 4-20).

4-18. Amplifier Card

Test an amplifier card as follows:

a. Turn the FUNCTION switch to AMPL OUP. Plug the card into the AMPLIFIER CARD TESTER receptacle, component-side down. Set the 115V 400 POWER switch to on (up) position.

b. Set the CARD TEST SIGNAL switch to L. Observe the FUNCTION meter for the required indication.

c. Set the CARD TEST SIGNAL switch to R. Observe the FUNCTION meter for the required indication.

d. If no further tests are to be performed stop the test set (para 4-20).

4-19. Calibration Card

Test a calibration card as follows:

NOTE

The CALIBRATION TEST POINTS connect to the corresponding pins of the CALIBRATION CARD test receptacle. Since the calibration card does not include complete functioning circuits, testing is limited to resistance and capacitance measurements.

a. Plug the card into the CALIBRATION test receptacle component-side down.

b. Refer to the SAS amplifier schematic diagram for circuit points and component values. Calibration card circuit configurations and component values are not the same for all SAS amplifier models.

c. Adjust the multimeter to the appropriate resistance range or adjust the C-I-R bridge to the appropriate capacitance range. Connect the test leads to the CALIBRATION TEST POINTS to be measured.

NOTE

The test of the ASE function of the calibration card is not applicable to the CH-47 SAS amplifiers.

d. Remove the card from the test receptacle.

e. If any measurements are not correct, repair or install a new card as necessary.

f. Stop the test set (para 4-20).

4-20. Stopping Procedure

4-21. Stop the test set as follows:

a. Set the 115V 400~POWER switch to off (down) position.

b. Disconnect all test and power cables from the test set.

c. Stow all cables and the adapter in the cover of the test set.

d. Close the hinged door. Secure it with the turnlock fasteners.

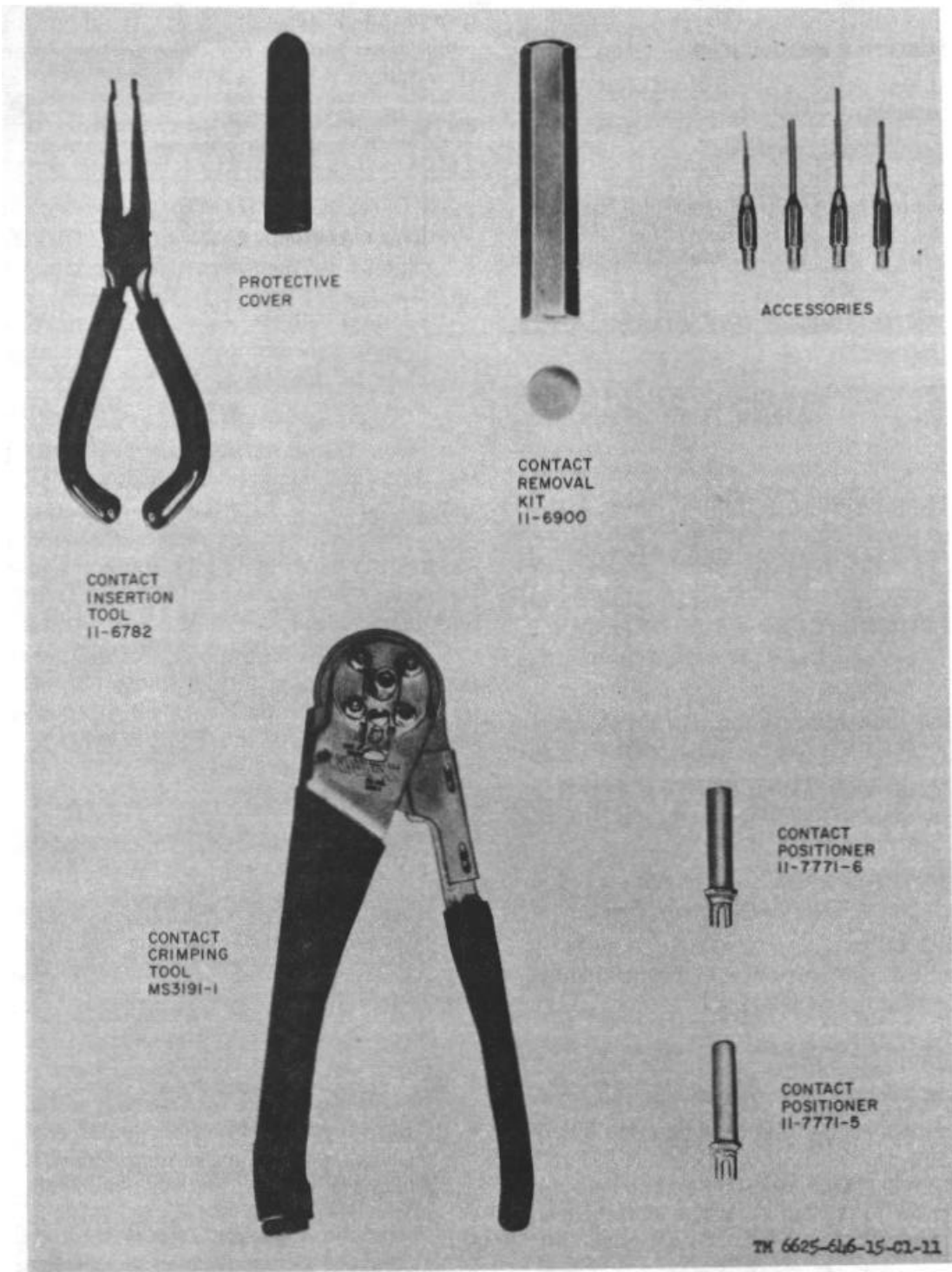

Figure 4-3. Connector contact tools.

- e. Close the instruction pages. Secure them with the retainer.
- f. Secure the instruction page retainer to the case.
- g. Secure the cover on the case.

4-22. Use of Connector Tools

4-23. (fig. 4-3). The test set includes a set of connector contact tools (table 1-1). These tools are used to remove and replace the solderless contacts of most crimp-type connectors.

- 4-24.** Remove a contact from a connector as follows:
- a. Use the contact removal kit 11-6900 with adapter 11-6783 in position for removing a pin-type contact. Use the kit with adapter 11-6784 in position for removing a socket-type contact.
 - b. Working from the contact side of the connector, push the contact back through the grommet and remove the disengaged contact.

NOTE
For additional connector installation and fabrication practices, refer to TM 5-1500-323-25.

- 4-25.** Install a contact in a connector as follows:
- a. Cut the replacement wire to length. Strip 3/16 inch of insulation from one end. Hotwire stripping is recommended. Avoid nicking the individual strands if another stripping method is employed.
 - b. Insert the bottom the wire in the contact. The wire insulation must extend into the insulation wire well support of the contact.
 - c. Check that the wire strands are visible in the contact inspection hole.
 - d. Make sure the correct size contact positioner is in the crimping tool MS3191-1. Insert the contact into the contact positioner. Close the handles of the crimping tool, apply pressure, and release.
 - e. After crimping, remove the wire and contact from the crimping tool.
 - f. Slide the contact into the channel of the contact insertion tool 11-6782. Make sure the rear of the insulation support butts against the internal shoulder of the tool tip.
 - g. Insert the contact into the rear face of the connector grommet.
 - h. Push the contact forward until it snaps into position in the connector. A slight pressure may be noticed until the contact reaches its fully seated position.
 - i. Release the holding pressure and remove the contact insertion tool.

Table 4-4. Main Connector Test Point Voltages

Test point		Channel	Voltage
A	Power.....		28 vdc
B	Power (114E3030-40, -42, -43, and -47).....		26 vac
B	Pitch gain control (114E33030-49).		
C	Ground		0
D	Gain control interlock to other SAS amplifier.....		28 vdc
E	Gain control ground.....	All channels.	
F	Gain control interlock from other SAS amplifier (HALF GAIN switch..... pressed).		28 vdc
G	Gain control relay ground.		
H	Output voltage (Measure to C).....		8 vdc
J	Output voltage.		
K	Output voltage (Measure to C).		
L	Secondary cancellation voltage.....	Yaw.	
M	Primary excitation voltage.		
N	Primary cancellation voltage.		
P	Primary excitation voltage.		

Test point		Channel	Voltage
R	Output voltage (Measure to C)		
S	Output voltage.		
T	Output voltage (Measure to C).....	Roll	
U	Secondary cancellation voltage.		
V	Primary excitation voltage.		
W	Primary cancellation voltage.		
X	Primary excitation voltage.		
Y	Output voltage (Measure to C)		
Z	Output voltage.		
a	Output voltage (Measure to C).....	Pitch.	
b	Secondary cancellation voltage.		
C	Primary excitation voltage.		
d	Primary cancellation voltage.		
e	Primary excitation voltage.		
f	Roll signal input (114E3030-49 only)	Roll.	
g	Sideslip indication	Yaw.	
h	Roll signal input (114E3030-49 only)	Roll.	
i	Power (114E3030-49 only)		115 vac
j	Roll signal input (114E3040-49 only)	Roll.	
k	Secondary excitation voltage (Measure to q).....	All channels.	
m	Gyromotor winding RG2.....	Roll.	
n	Gyromotor winding RG2.		
p	Power.....	All channels	26 vac
q	Secondary excitation voltage (Measure to k).		
r	Gyromotor winding RG1	Pitch.	
s	Gyromotor winding RG1.		
t	Sideslip indication	Yaw.	

(Next printed page is 39)

SECTION V

PERIODIC INSPECTION, MAINTENANCE, AND LUBRICATION

5-1. SCOPE OF MAINTENANCE. The maintenance duties assigned to the operator of the equipment are listed below together with a reference to the paragraphs covering the specific maintenance functions.

5-1.1. Daily preventive maintenance checks and services are covered in paragraph 5-2.4.

5-1.2. Weekly preventive maintenance checks and services are covered in paragraph 5-2.5.

5-1.3. Quarterly preventive maintenance checks and services are covered in paragraph 5-2.6.

5-1.4. Cleaning procedures are covered in paragraph 5-2.7.

5-1.5. Touchup painting information is covered in paragraph 5-2.11.

5-2. PREVENTIVE MAINTENANCE. Preventive maintenance is the systematic care, servicing, and inspection of equipment to prevent the occurrence of trouble, to reduce downtime, and to assure that the equipment is serviceable.

5-2.1. SYSTEMATIC CARE. The procedures given in paragraphs 5-2.4 through 5-2.10 cover routine systematic care and cleaning essential to proper upkeep and operation of the equipment.

5-2.2. PREVENTIVE MAINTENANCE CHECKS AND SERVICES. The preventive maintenance checks and services charts (para 5-2.4, 5-2.5 and 5-2.6) outline the functions to be performed at specific intervals. These checks and services are to maintain Army electronic equipment in a combat serviceable condition; that is, in good general (physical) condition and in good operating condition. To assist operators in maintaining combat serviceability, the charts indicate what to check, how to check, and what the normal conditions are; the References column lists the illustrations, paragraphs, or manuals that contain detailed repair or replacement procedures. If the defect cannot be remedied by performing the corrective actions listed, higher level maintenance or repair is required. Records and reports of these checks and services must be made in accordance with the requirements set forth in TM 38-750.

5-2.3. PREVENTIVE MAINTENANCE CHECKS AND SERVICES PERIODS. Preventive maintenance checks and services of the equipment are required daily, weekly, and quarterly.

5-2.3.1. Paragraph 5-2.4 specifies the checks and services that must be accomplished daily (or at least once each week if the equipment is maintained in a standby condition).

5-2.3.2. Paragraphs 5-2.5 and 5-2.6 specify additional checks and services that must be performed on a weekly and quarterly basis, respectively.

5-2.4. DAILY PREVENTIVE MAINTENANCE CHECKS AND SERVICES CHART.

Sequence No.	Items to be Inspected	Procedure	References
1	Completeness	Check for completeness of the equipment.	Appendix III, figure 1-1
2	Exterior surfaces	Clean the exterior surfaces, including the front panel of the test set and meter glass. Check meter glass for cracks.	Paragraph 5-2.7
3	Cable assemblies	Check the cable assemblies for moisture and dirt.	Figure 1-1.
4	Connector tools	Check for corrosion and apply a light coat of preservative oil.	Paragraph 5-2.7, figure 1-1 and 4-3.
5	Controls and indicators	While making operational checks (6 below), observe that the mechanical action of each knob and switch is smooth and free from internal and external binding, and that there is no excessive looseness. Check meters for sticking and bent pointers. Check indicator lamps for damaged lens.	Figure 4-1.
6	Operation	Check for normal operation of the test set.	Section IV.

5-2.5. Weekly Preventive Maintenance Checks and Services Chart

Sequence No.	Item	Procedure	References
1	Exterior surfaces	Inspect exposed metal surfaces for rust and corrosion. Touch up paint as required. Inspect cables for cracked, chafed, or frayed insulation. Inspect connectors for damage or defects; replace or repair as necessary. Inspect canvas bag for deterioration and fungus growth. Inspect for tears, repair as indicated in TM 10-269, replace deteriorated items, and wash fungus covered items with mild soap and water and dry completely.	Paragraph 5-2.11
2	Cable assemblies		Para 4-22
3	Canvas items .		TM 10-269

5-2.6. Quarterly Preventive Maintenance Checks and Services Chart

Sequence No.	Item	Procedure	References
1	Completeness	See that all publications are complete, serviceable, and current. Check DA Pam 310-7 to determine existence of applicable MWO's. Check the equipment to determine if MWO's have been performed. All URGENT MWO's must be applied immediately; NORMAL MWO's must be scheduled.	DA Pam 310-4
2	Modifications		TM 38-750, DA Pam 310-7

5-2.7. CLEANING. Inspect the exterior of the equipment. The exterior surfaces should be free of dust, dirt, grease, and fungus. Remove dust and loose dirt with a clean soft cloth.

WARNING

Cleaning compound is flammable and its fumes are toxic. Provide adequate ventilation; do not use near a flame.

5-2.8. Remove grease, fungus, and ground-in dirt from the equipment; use a cloth dampened with (not wet) Cleaning Compound (Federal stock No. 7930-395-9542).

5-2.9. Remove dust and dirt from plugs and jacks with a soft brush.

CAUTION

Do not press on the meter faces (glass) when cleaning; the meters may become damaged.

5-2.10. Clean the front panel, meters, and control knobs and switches; use a soft clean cloth. If necessary, dampen the cloth with water; mild soap may be used for more effective cleaning.

5-2.11. TOUCHUP PAINTING. Remove rust and corrosion from metal surfaces by lightly sanding them with fine sandpaper. Brush two thin coats of paint on the bare metal to protect it from further corrosion. Refer to the applicable cleaning and refinishing practices specified in TM 9-213.

5-3. LUBRICATION. No lubrication is required.

5-4. ADJUSTMENTS. Refer to Section VII, Calibration, for adjustment requirements.

SECTION VI TROUBLESHOOTING AND PARTS REPLACEMENT

6-1. Troubleshooting Procedures

6-2. General

During troubleshooting, observe the following precautions and procedures:

- a. Perform continuity checks with all electrical power OFF.
- b. Unless otherwise specified, measure voltages to ground (chassis) with a 20,000-ohm-per-volt multimeter.
- c. When unsoldering and removing parts such as meters or rotary switches, note carefully the position of the connecting wires. Tag each wire before unsoldering.
- d. When replacing components, installed on the underside of the test set chassis, be careful not to loosen wires or damage adjacent components.
- e. Solder connections carefully; poorly soldered connections can result in intermittent operation.
- f. When soldering wires to the test meters, use a heat sink and a soldering iron with a rating of not more than 40 watts.
- g. When removing or installing a printed-wiring card, be careful not to damage components on the card or those on adjacent cards.

6-3. Test Equipment Required

Refer to paragraph 7-3.

6-4. Troubleshooting Tables

Three troubleshooting tables are included to enable the electronic technician to locate and correct trouble in the test set. Table 6-1 covers all the test meter circuits. Table 6-2 covers the internal and external card test circuits. Table 6-3 covers the miscellaneous test circuits. Use the schematic diagrams (figs. 1-2 through 1-7), and the wiring diagrams (figs. 6-1 through 6-4), as aids during troubleshooting.

6-5. Parts Replacement

6-6. Test set components are accessible when the panel-chassis is removed from its case. Except for items in paragraphs 6-7 through 6-11, all components can be replaced without special instructions.

6-7. Replacement of Air Pump Assembly (fig. 6-5)

Replace the air pump assembly as follows:

- a. Remove the panel-chassis from its case.
- b. Disconnect the plumbing and the electrical wires from the pump.
- c. Remove the defective pump.
- d. Refer to TM 11-6625-614-45 for repair of the air pump assembly.
- e. Install the replacement pump.
- f. Connect the plumbing to the pump. Connect the electrical wires.
- g. Check pump operation to ensure it is functioning properly.
- h. Reinstall the panel-chassis in the case.

6-8. Replacement of Regulator Valves

Replace the regulator valve as follows:

- a. Remove the control knob from the valve shaft.
- b. Remove the panel-chassis from its case.
- c. Remove the bottom pan from the chassis.
- d. Disconnect the plumbing from the valve.
- e. Remove the attaching hardware from the valve and withdraw the valve from the chassis. Discard the faulty valve and gasket; retain the hardware.

Table 6-1. Meter Test Circuit Troubleshooting

Trouble	Probable cause	Remedy
Function meter M1 does not indicate in the green area; FUNCTION switch at DC PWR and 25 vdc test voltage is connected between MAIN CONNECTOR TEST POINTS A(+) and C(-)	Defective meter multiplier resistor R201 or defective wiring.	Measure the resistance of R201; check for continuity between R201 and J60-A and M1+. Replace the resistor or repair wiring as required.
Function meter M1 does not indicate in the green area; FUNCTION switch at AC PWR and 115 vac test voltage is connected between MAIN CONNECTOR TEST POINTS i and C.	No ground return on function meter circuit.	Check continuity to ground from the negative terminal of function meter M1. Repair wiring, clean or replace switch S7 as required.
	Function meter defective	Check the meter at several positions of switch 57 and observe the meter for proper operation. Replace the meter if found defective.
Function meter M1 does not indicate in the green area; FUNCTION switch at AC PWR and 115 vac test voltage is connected between MAIN CONNECTOR TEST POINTS i and C.	Calibrating resistor R406, shunt resistor R407, or meter rectifier stage defective.	Replace component card A02V3068. If this does not correct the trouble, reinstall the original card.
Function meter M1 does not indicate in the green area; FUNCTION switch at INTLK and 28 vdc test voltage is connected between MAIN CONNECTOR TEST POINTS D(+) and	No ac voltage at input to metering circuit.	Check for 26 volts ac between pins 12 and 13 of J68. If voltage is not present, troubleshoot the circuit to T501. Check resistance to ground from pin 11 of J68. If resistance is not 750 ohms, troubleshoot the circuit through switch S7.
Function meter M1 does not indicate in the green area; FUNCTION switch at INTLK and 28 vdc test voltage is connected between MAIN CONNECTOR TEST POINTS D(+) and	Function meter defective	Check the meter at several positions of switch S7 and observe the meter for proper operation. Replace the meter if found defective.
Function meter M1 does not indicate in the green area; FUNCTION switch at INTLK and 28 vdc test voltage is connected between MAIN CONNECTOR TEST POINTS D(+) and	Meter multiplier resistor R202 defective.	Replace component card A02V3060. If this does not correct the trouble, reinstall the original card.
Function meter M1 does not indicate in the green area; FUNCTION switch at DEM OUPT and 3.9 vdc test voltage is connected between pins 15(-) and 17(+) of J69.	Faulty wiring between pin jacks D and C and the function meter M1.	Check continuity between the pin jacks and the multimeter. Repair wiring as required.
Function meter M1 does not indicate in the green area; FUNCTION switch at DEM OUPT and 3.9 vdc test voltage is connected between pins 15(-) and 17(+) of J69.	Test voltage not properly connected to J69.	Check the test voltage at J69 and that the test voltage is properly connected.
Function meter M1 does not indicate in the green area; FUNCTION switch at DEM OUPT and 3.9 vdc test voltage is connected between pins 15(-) and 17(+) of J69.	Load resistors R302, R303, or meter multiplier resistor R304 defective.	Replace component card A02V3064. If this does not correct the trouble, reinstall the original card.

Trouble	Probable cause	Remedy
Function meter M1 does not indicate in the green area; FUNCTION switch at AMPL OUART and 3.8 vdc test voltage is connected between pins 15(-) and 17(+) of J71.	<p>Faulty wiring between J69 and J67, between J67 and switch S7 or between switch S7 and Meter M1.</p> <p>Defective switch S7</p> <p>Test voltage not properly connected to J71.</p>	<p>Check continuity of circuits; repair wiring as required.</p> <p>Clean or replace switch.</p> <p>Check the test voltage at J71 and that the test voltage is properly connected.</p>
Function meter M1 does not indicate in the green area; FUNCTION switch at ROLL FEEDBACK POT. EXCITATION and external 2.5 vac test signal connected between MAIN CONNECTOR TEST POINTS X and V.	<p>Load resistors R305, R306 or meter multiplier resistor R307 defective.</p> <p>Faulty wiring between J69 and J67, between J67 and switch S7, or between switch S7 and meter M1.</p> <p>Defective switch S7 .</p> <p>Defective meter rectifier stage or meter multiplier resistor R403.</p>	<p>Replace component card A02V3064. If this does not correct the trouble, reinstall the original card.</p> <p>Check continuity of the circuits; repair wiring as required.</p> <p>Clean or replace switch.</p> <p>Replace component card A02V3068. If this does not correct the trouble, reinstall the original card.</p>
Function meter M1 does not indicate in the green area; FUNCTION switch at PITCH FEEDBACK POT. EXCITATION and external 2.5 vac test voltage is connected between MAIN CONNECTOR TEST POINTS e and c.	<p>Faulty wiring or defective switch S5 or S7.</p> <p>Defective meter rectifier stage or meter multiplier resistor R404.</p>	<p>Check continuity through the circuit (fig. 1-4). Repair wiring; clean or replace switches as required.</p> <p>Replace component card A02V3068. If this does not correct the trouble, reinstall the original card.</p>
Function meter M1 does not indicate in the green area; FUNCTION switch in SEC FEEDBACK POT. EXCITATION and 2.5 vac test voltage is connected between MAIN CONNECTOR TEST POINTS q and k.	<p>Faulty wiring or defective switch S5 or S7.</p> <p>Defective meter rectifier stage or multiplier resistor R405 defective.</p> <p>Faulty wiring or defective switch S5 or S7.</p>	<p>Check continuity through the circuit (fig. 1-4). Repair wiring, clean or replace switches as required.</p> <p>Replace component card A02V3068. If this does not correct the trouble, reinstall the original card.</p> <p>Check continuity through the circuit (fig. 1-4). Repair wiring, clean, or replace switches as required.</p>

Trouble	Probable cause	Remedy
Function meter M1 does not indicate in the green area; FUNCTION switch at YAW FEEDBACK POT. EXCITATION and a 2.5 vac test voltage is connected between MAIN CONNECTOR TEST POINTS M and P.	Defective meter rectifier stage or multiplier resistor R402.	Replace component card A02V3068. If this does not correct the trouble, reinstall the original card.
YAW AXIS meter M2 does not indicate when yaw channel voltages are being simulated by external test signals.	Faulty wiring or defective switch S5 or S7.	Check continuity through the circuit. (fig. 1-4). Repair wiring, clean, or replace switches as required.
YAW AXIS meter M2 does not indicate when yaw channel voltages are being simulated by external test signals.	Defective actuator-simulator card in J63.	Replace the yaw channel actuator-simulator card. If this does not correct the trouble, reinstall the original card
YAW AXIS meter M2 does not indicate when yaw channel voltages are being simulated by external test signals.	Defective internal dc power supply	Replace component card A02V3060. If this does not correct the trouble, reinstall the original card.
YAW AXIS meter M2 does not indicate when yaw channel voltages are being simulated by external test signals.	Defective signal input or power wiring.	Check signal input and power wiring to J63.
YAW AXIS meter M2 does not indicate when yaw channel voltages are being simulated by external test signals.	Defective wiring to metering circuit.	Check the wiring between the meter and pins 20 and 23 of J63. Repair the wiring as required.
ROLL AXIS meter M3 does not indicate when roll channel voltages are being simulated by external test signals.	Defective meter M2 Defective circuits on the actuator-simulator card in J64.	Replace defective meter. Replace the roll channel actuator-simulator card. If this does not correct the trouble, reinstall the original card.
ROLL AXIS meter M3 does not indicate when roll channel voltages are being simulated by external test signals.	Defective internal power supply	Replace component card A02V3060. If this does not correct the trouble, reinstall the original card.
ROLL AXIS meter M3 does not indicate when roll channel voltages are being simulated by external test signals.	Defective signal input or power wiring.	Check signal input and power wiring to J64.
ROLL AXIS meter M3 does not indicate when roll channel voltages are being simulated by external test signals.	Defective wiring to metering circuit.	Check the roll axis meter circuit from the meter through adapter switch S5 to pins 20 and 23 of J64. Repair wiring as required.
PITCH AXIS meter M4 does not indicate when pitch channel voltages are being simulated by external test signals.	Defective meter M3 Defective circuits on the actuator-simulator card in J65.	Replace defective meter. Replace the pitch channel actuator-simulator card. If this does not correct the trouble, reinstall the original card.
PITCH AXIS meter M4 does not indicate when pitch channel voltages are being simulated by external test signals.	Defective internal power supply	Replace component card A02V3060. If this does not correct the trouble, reinstall the original card.
PITCH AXIS meter M4 does not indicate when pitch channel voltages are being simulated by external test signals.	Defective signal input or power wiring.	Check signal input and power wiring to J65.
PITCH AXIS meter M4 does not indicate when pitch channel voltages are being simulated by external test signals.	Defective wiring to metering circuit.	Check the pitch axis meter circuit from the meter through adapter switch S5 to pins 20 and 23 of J65. Repair wiring as required.
PITCH AXIS meter M4 does not indicate when pitch channel voltages are being simulated by external test signals.	Defective meter M4	Replace defective meter.

- f. Install a replacement valve with a new gasket.
- g. Connect the plumbing to the valve.
- h. Install the bottom pan on the chassis.
- i. Reinstall the chassis in the case.

6-9. Replacement of Tube Assemblies

Replace a tube assembly as follows:

- a. Remove the chassis from its case.
- b. Remove the bottom pan from the chassis.
- c. Replace the tube assembly and associated fittings. (Refer to TM 55-405-7 for detailed instructions on fabricating tube assemblies.)
- d. Install the bottom pan on the chassis.
- e. Reinstall the chassis in the case.

6-10. Replacement of Air Gages

Replace an air gage as follows:

- a. Remove the chassis from the case to gain access to the gage.

- b. Remove the bottom pan from the chassis.
- c. Remove the two card retainers.
- d. Carefully withdraw the seven component (plug-in) cards from their receptacles.
- e. Disconnect the tube assemblies from the gage.
- f. Remove the attaching hardware and withdraw the gage from the panel. Retain the hardware.
- g. Install a replacement gage in its mounting hole in the panel.
- h. Connect the tube assemblies to the air gage.
- i. Reinstall the seven component cards in their respective receptacles. Make certain that each card is in its proper position.
- j. Align the cards and install the two card retainers.
- k. Install the bottom pan on the chassis.
- l. Reinstall the chassis in the case.

Table 6-2. Internal and External Card Test Circuit Troubleshooting.

Trouble	Probable cause	Remedy
Function meter M1 does not indicate in the red area; FUNCTION switch at AMPL OUP T and CARD TEST SIGNAL switch S6 operated to L or R.	No test signal available at pin 6 of J71. Defective internal ac power supply Check for 27 volts dc at pin 7 and for 8 volts ac at pin 19 of J71. Faulty wiring in the metering circuit or defective FUNCTION switch.	Replace component card A02V3064. If this does not correct the trouble, reinstall the original card; troubleshoot the wiring to J67-13 and the wiring to S6. Check for 26 volts ac at pin 18 of J67. If 26 volts ac is not present, troubleshoot the ac power supply. Troubleshoot the B+ and reference voltage circuits. Troubleshoot the circuits between pins 13, 15, and 17 of J71 and pins 7, 8, and 9 of J67. Troubleshoot the circuit from pin 10 of J67 to FUNCTION switch S7. Repair wiring as required. If switch S7 is defective, replace it.
Resistance between pins 1 and 7 of J70 is not 100K ohms $\pm 5\%$.	Defective wiring or defective resistor R205 on component card A02V3060.	Repair wiring or replace resistor R205.
Ac voltage between pins 12 and 18 of J70 is not 26 vac.	Defective internal power supply	Check for 115 vac between MAIN CONNECTOR TEST POINTS i and C. If voltage is

Trouble	Probable cause	Remedy
		not present check for 26 vac between terminals 3 and 5 of transformer T501. Replace the transformer or troubleshoot the 115-volt or 26-volt power wiring as required.

Table 6-3. Miscellaneous Test Circuit Troubleshooting

Trouble	Probable cause	Remedy
115V 400~ POWER indicator lamp does not come on when switch S1 is operated to the on position.	Defective lamp DS1 or circuit breaker switch S1.	Check the lamp and replace if defective. If the lamp is good, check for 115 volts ac at terminal 1 and at terminal 2 of switch S1; if the voltage is normal at terminal 1 but not present at terminal 2, replace the switch.
	Defective wiring or broken connection at connector J62 or open circuit in power cable A02VS309-3.	If the voltage is not present at contact 1 of S1, check the voltage at the power source; if the source voltage is normal, check continuity through connector J62 and power cable A02VS309-3; repair as required.
No 26 volts ac between DEM/ MOD CARD TESTER receptacle J70 pins 18 and 12.	Defective wiring or connection between transformer T501 and J70-18.	Check for 26 volts ac at terminal 3 of power transformer T501. If the voltage is normal, troubleshoot the circuit between the transformer and J70-18. Repair wiring as required.
No 27 volts dc between MAIN CONNECTOR TEST POINTS A(+) and C(-).	Open circuit between the internal dc power supply and TEST POINT A.	Check for 27 volts dc at J66 pin 9. If voltage is present, troubleshoot the circuit from J66 pin 9 to TEST POINT A. Repair wiring as required.
	Defective resistor R204 or broken connection.	If voltage is not present at J66 pin 9, check for approximately 32 volts dc at J66 pin 8. If voltage is present, check resistor R204 and connector wiring. Repair wiring or replace resistor R204 as required.
DC voltage between MAIN CONNECTOR TEST POINTS A(+) and C (-) exceeds 28.5 volts.	Defective Zener diode CR501	Replace the diode.
DC voltage between MAIN CONNECTOR TEST POINTS A(+) and C(-) less than 25.5 volts.	Defective internal power supply component.	Replace card A02V3060. If this does not correct the trouble, reinstall the original card and troubleshoot the wiring to J66. Repair wiring as required.
No 32 volts dc ± 4 indicated on external multimeter connected	Defective switch S3 or associated wiring.	Check for approximately 32 volts dc at pin 8 of J66. If dc voltage

Trouble	Probable cause	Remedy
between MAIN CONNECTOR TEST POINTS F(+) and C(-) when HALF GAIN switch S3 is depressed.		is present, troubleshoot the circuit through switch S3 to TEST POINT F.
PUMP power indicator lamp does not come on and pump does not operate when switch S2 is operated to the on (up) position.	<p>Defective component card A02V8060.</p> <p>Defective 26 volts ac distribution circuit.</p> <p>Broken connections between circuit breaker switch S2 and motor or defective switch.</p>	<p>If dc voltage is not present, check for 26 volts ac at pin 14 of J66.</p> <p>If ac voltage is present, replace the card.</p> <p>If 26 volts ac is not present, Troubleshoot the circuit to power transformer T501.</p> <p>Check for 115 volts ac at terminal 2 of switch S2. If the voltage is normal, troubleshoot the circuit through the switch to terminal B on the motor; repair broken connection or replace the switch as required.</p>
PUMP power indicator lamp comes on but PUMP does not operate when switch is operated to the on (up) position.	<p>Broken connection at connector J61 or in power cable.</p> <p>Defective pump motor .</p>	<p>If the voltage is not present at contact 2 of S2, check the voltage at the power source. If the source voltage is normal, check continuity through connector J61 and power cable A02VS309-2; repair as required.</p> <p>Check for 115 volts ac between terminals A and B of the motor. If the voltage is normal, replace the pump.</p>
Indication on AIRSPEED indicator remains at 0 as AIRSPEED REG knob is operated.	<p>Note. The following troubleshooting procedures are also applicable to the DIFF PRESSURE Indicator and It associated regulator valve and tubing.</p> <p>Pump is not operating</p> <p>Tubing is loose or broken</p> <p>Defective regulator valve</p> <p>Blocked tubing to the indicator or a defective indicator.</p>	<p>Troubleshoot the power wiring to the pump. Repair as required.</p> <p>If the pump is operating, check for an air pressure indication on the field tester airspeed indicator. If there is no indication, check for loose or broken tubing. Tighten or replace as required.</p> <p>If the tubing is intact, disconnect the pressure connection on the pump side of the valve and check for pressure. If the pressure is present, replace the valve.</p> <p>If the field tester airspeed indication is normal, remove the tubing between the AIRSPEED indicator, the regulator valve, and the pump. Check that the tubing is clear of foreign matter. If the tubing is clear, replace the indicator.</p>
AIRSPEED indicator out of calibration.	<p>Defective indicator</p>	<p>Check the AIRSPEED indication when the pump is not operating.</p>

Trouble	Probable cause	Remedy
Indication on DIFF PRESSURE indicator remains at 0 as DIFF PRESS REG knob is operated.	<p>Pump is not operating .</p> <p>Tubing is loose or broken</p> <p>Defective regulator valve.</p> <p>Blocked tubing to the indicator or a defective indicator.</p>	<p>If the pointer is not on 0, adjust the zero-adjusting screw and repeat the calibration check of the indicator. If the indication is 0, replace the defective indicator.</p> <p>Troubleshoot the power wiring to the pump. Repair as required.</p>
DIFF PRESSURE indicator out of calibration.	Defective indicator	<p>If the pump is operating, check for differential pressure indication on the field tester gage; if there is no indication, check for loose or broken tubing. Tighten or replace tubing as required.</p> <p>If the tubing is intact, disconnect the air connection on the pump side of the valve and check for pressure. If pressure is available, replace the valve.</p> <p>If the field tester gage indication is normal, remove the tubing between the indicator, the regulator valve, and the pump. Check that the tubing is clear of foreign matter. If tubing is clear, replace the indicator.</p> <p>Check the DIFF PRESSURE indication when the pump is not operating. If the pointer is not at 0 adjust the zero-adjusting screw and check the calibration of the indicator. If the indication is 0, replace the defective indicator.</p>
PITCH AXIS meter indications not as specified as adapter GAIN SWITCH is operated.	Defective GAIN SWITCH S102 -	<p>Check for continuity between adapter receptacle J101 pins B and C with switch S102 at AIR. If continuity is not present, replace switch S102.</p>
ROLL AXIS meter indications not as specified as adapter ROLL GYRO SIMULATOR switch is operated.	<p>Defective transformer T101</p> <p>Defective resistor R101 through R104. Defective switch S101.</p>	<p>Check the resistance of T101 windings (table 6-4). If resistances are not as specified, replace T101.</p> <p>Troubleshoot resistors and replace as required. Check continuity through switch contacts (fig. 1-7). If continuity is not as required, replace switch S101.</p>

Table 6-4. Dc Resistance of Transformers

Reference designation	Part number	Wire color or terminal number	Dc resistance In ohms ($\pm 10\%$)
T301	DO-T23	Yellow to green	100
T401		Brown to blue	830
T603	DO-T25	Yellow to green	125
T604		Brown to red.....	750
T402	DO-T36	Brown to blue	876
T601		Yellow to green	1100
T602	DO-T39	Brown to blue	650
T605		Brown to red.....	350
T101 (adapter)	DO-T39	Yellow to white	45
		Black to green.....	55
		1 to 2	11
T501	TW-25F26T	3 to 5	0.6

6-11. Replacement of Printed Circuit Cards

Replace a print-wiring or component card as follows:

- a. Remove the panel-chassis from its case.
- b. Remove the card retainer.
- c. Withdraw the card from its receptacle by pulling it straight out.

CAUTION

When removing or installing a card, be careful not to damage components of the card or those of adjacent cards.

- d. Install the replacement card in its receptacle.
- e. Align the cards and reinstall the card retainer.
- f. Reinstall the panel-chassis in the case.

6-12. Repairs**6-13. Card Repairs**

Repair a printed-wiring card as follows:

- a. Two types of card defects are repairable: defective components and defective conductors. Discard broken, cracked, or blistered cards.

CAUTION

Use a pencil-type soldering iron with a maximum rating of 25 watts when repairing printed-wiring cards.

- b. The printed-wiring cards are coated with protective coating EC 1103. Remove the protective coating from the immediate area before repairs are

attempted. When repairs are completed, apply new protective coating. Proceed as follows to remove or apply protective coating:

WARNING

Protective coating EC 1103 is toxic. The work area must be well ventilated. Avoid breathing the fumes. If the coating comes in contact with the skin, wash the affected area with soap and water immediately.

- (1) *Removal of protective coating.*

(a) If repairs are extensive, soak the card in trichloroethylene to soften the protective coating. Wipe the area clean with a lint free cloth.

(b) If repairs are minor, carefully scrape the protective coating from the area to be repaired using a knife or similar sharp tool.

- (2) *Application of protective coating.*

(a) Clean the repaired area thoroughly using a rubber eraser.

(b) Prepare the protective coating by mixing 70 parts of volume of coating EC 1103 with 30 parts by volume of naphtha. Stir the mixture thoroughly.

(c) Apply the protective coating to the card by spraying, dipping, or brushing. When brushing

Figure 6-1. SAS bench test set, wiring diagram.

(Located in back of manual.)

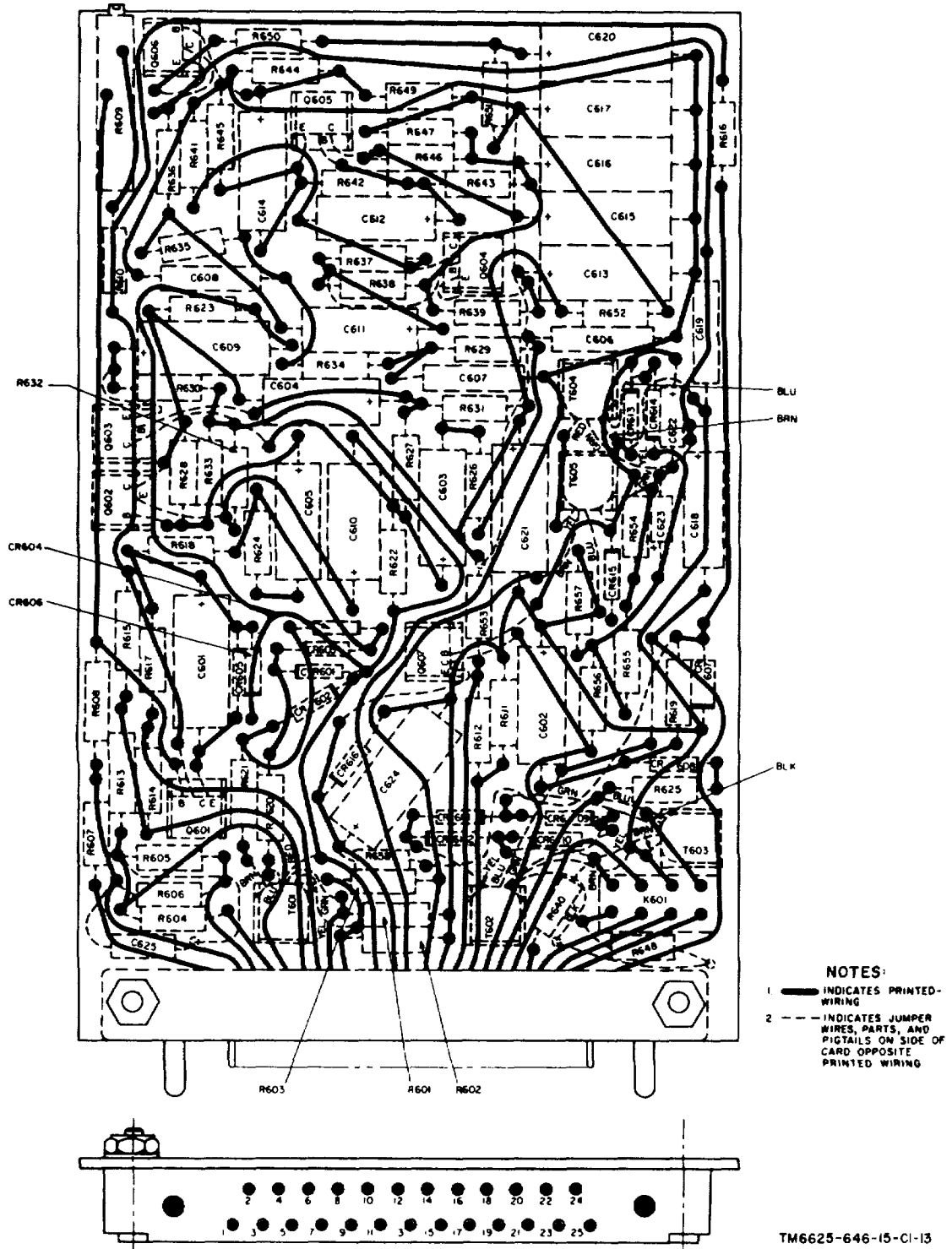

TM6625-646-15-C1-13

Figure 6-2. Actuator-simulator card, wiring diagram.

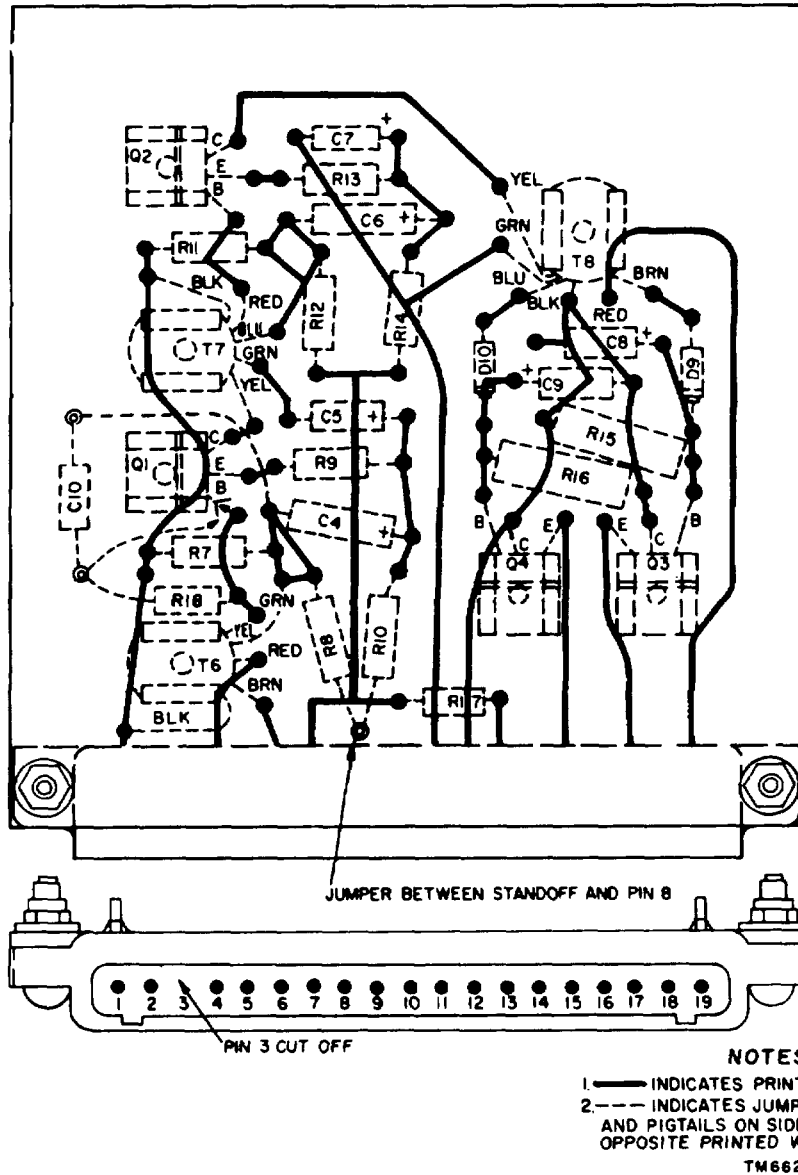

Figure 6-3. Amplifiers card, wiring diagram.

the coating on the card do not allow bubbles to form.

(d) Allow the card to dry in air for 5 hours before installing it in the test set.

c. A printed-wiring conductor that has a hole, cut, or notch that exceeds 30 percent of its width is defective and must be repaired. Repair a defective conductor as follows:

(1) Remove the protective coating as directed in b above.

(2) Place a short length of flat bus wire over the defect in the conductor and hold it firmly in place.

(3) Solder the entire length of the bus wire to the conductor.

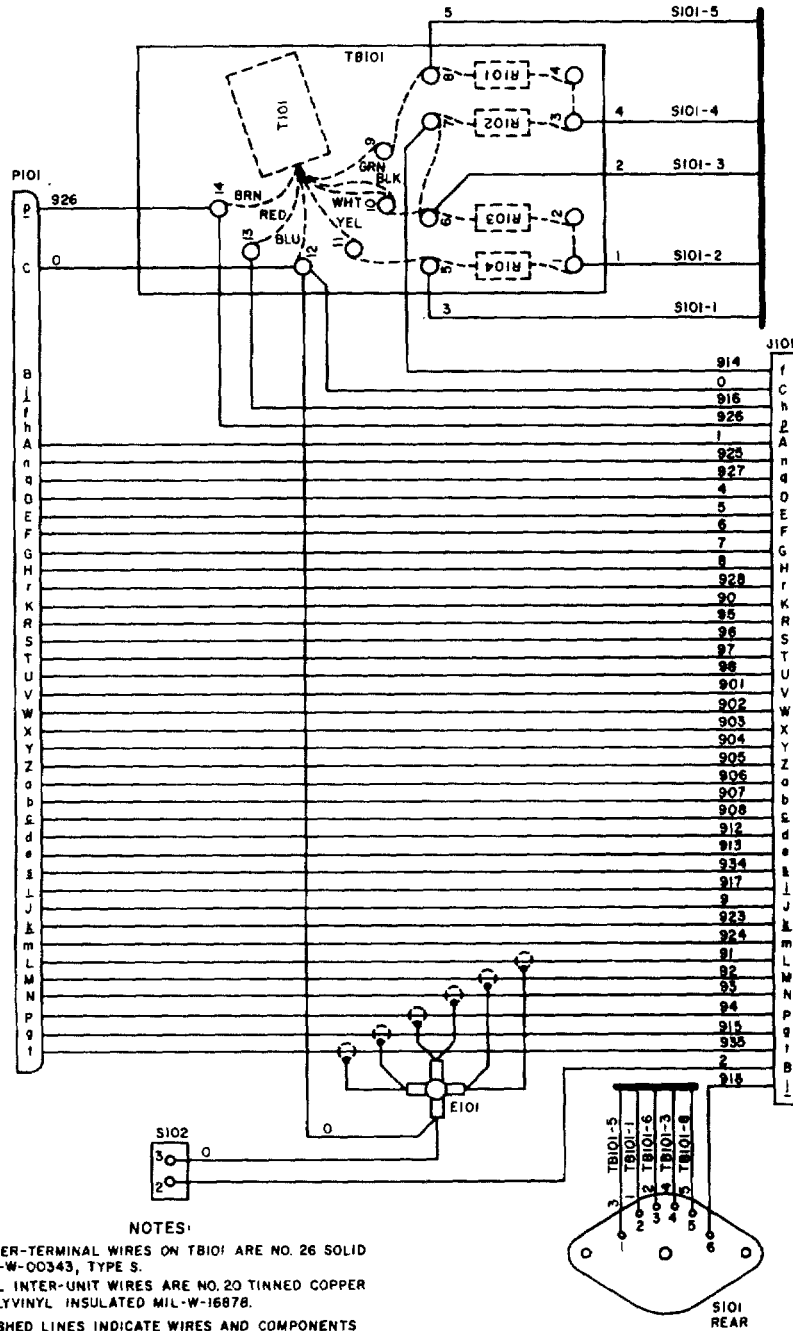

NOTES:

1. INTER-TERMINAL WIRES ON TB101 ARE NO. 26 SOLID QQ-W-00343, TYPE S.
2. ALL INTER-UNIT WIRES ARE NO. 20 TINNED COPPER POLYVINYL INSULATED MIL-W-16878.
3. DASHED LINES INDICATE WIRES AND COMPONENTS ON OPPOSITE SIDE OF TB101.
4. NUMBER NEAREST EACH WIRE TERMINATION INDICATES ITS COLOR AS FOLLOWS:

0 - BLACK	5 - GREEN
1 - BROWN	6 - BLUE
2 - RED	7 - PURPLE OR VIOLET
3 - ORANGE	8 - GRAY
4 - YELLOW	9 - WHITE

TM 6625-646-15-C1-19

Figure 6-4. SAS adapter, wiring diagram.

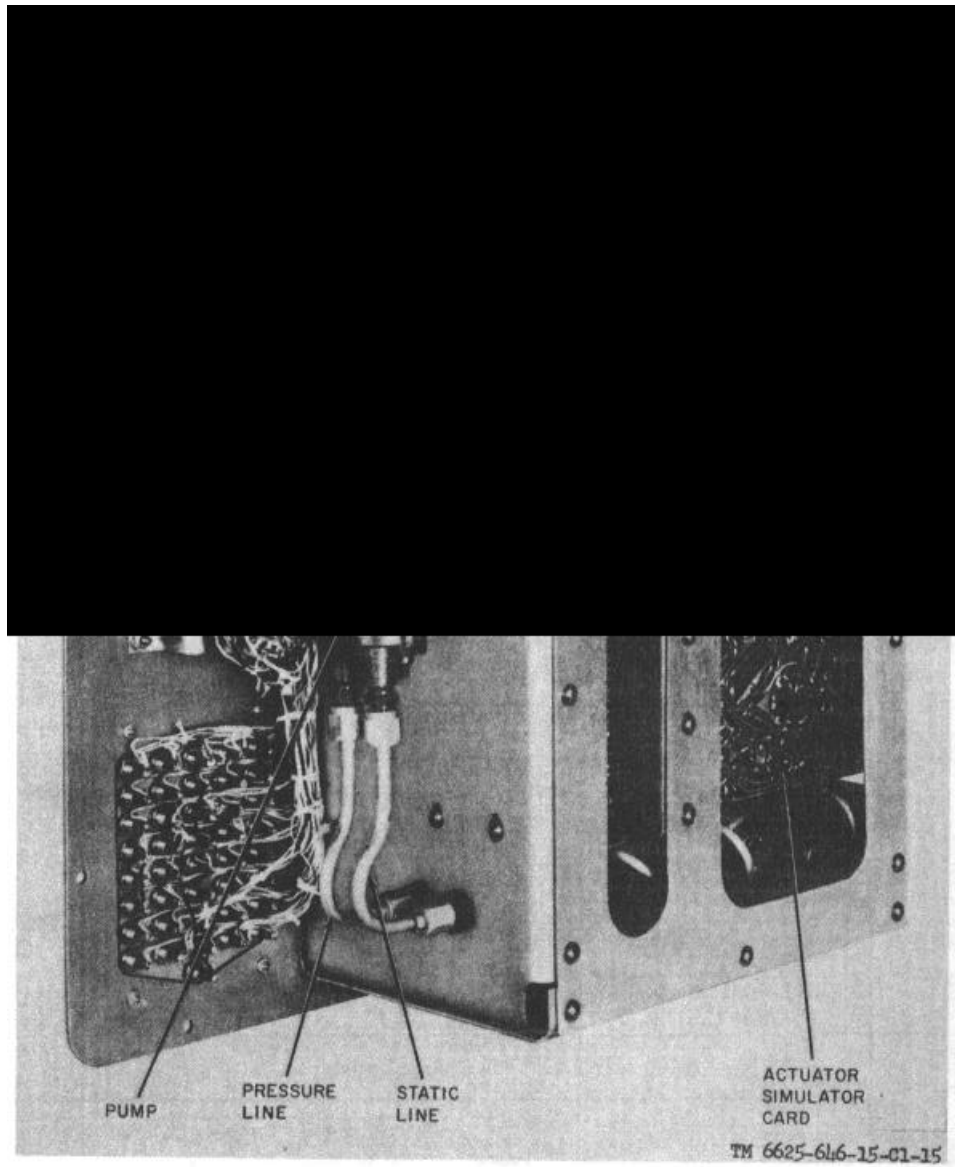

Figure 6-5. Left-rear view, SAS bench test set.

CAUTION

Do not apply heat longer than necessary, prolonged heating may damage the printed-wiring card. If heating causes the conductor to separate from the board, discard the card.

(4) Coat the repaired area with protective coating as directed in *b* above.

d. Replace a defective part as follows:

(1) Remove the protective coating as directed in step *b*.

(2) Apply heat at the component mounting holes until the solder is melted. Then remove the component and wire leads.

CAUTION

Do not apply heat longer than

necessary. Prolonged heating can damage the card.

(3) Heat the remaining solder in the mounting holes and remove it with a stiff bristle brush.

(4) Bend the replacement component leads to fit the mounting holes.

(5) Insert leads in the mounting holes and press the component firmly against the card.

(6) Cut the leads approximately 1/8 inch from the wiring side of the card.

(7) Bend and press the leads against the conductor.

(8) Using a heat sink, solder the leads to the conductor.

(9) Coat the new part and the repaired area with protective coating as directed in b above.

6-14. Connector Repairs

Refer to paragraph 4-22.

6-15. Selection of Values for Actuator Simulator Card Capacitor C607 and Resistor R648

Capacitor C607 and resistor R648 in the filter and meter rectifier circuits, respectively, are selected. When any actuator simulator card

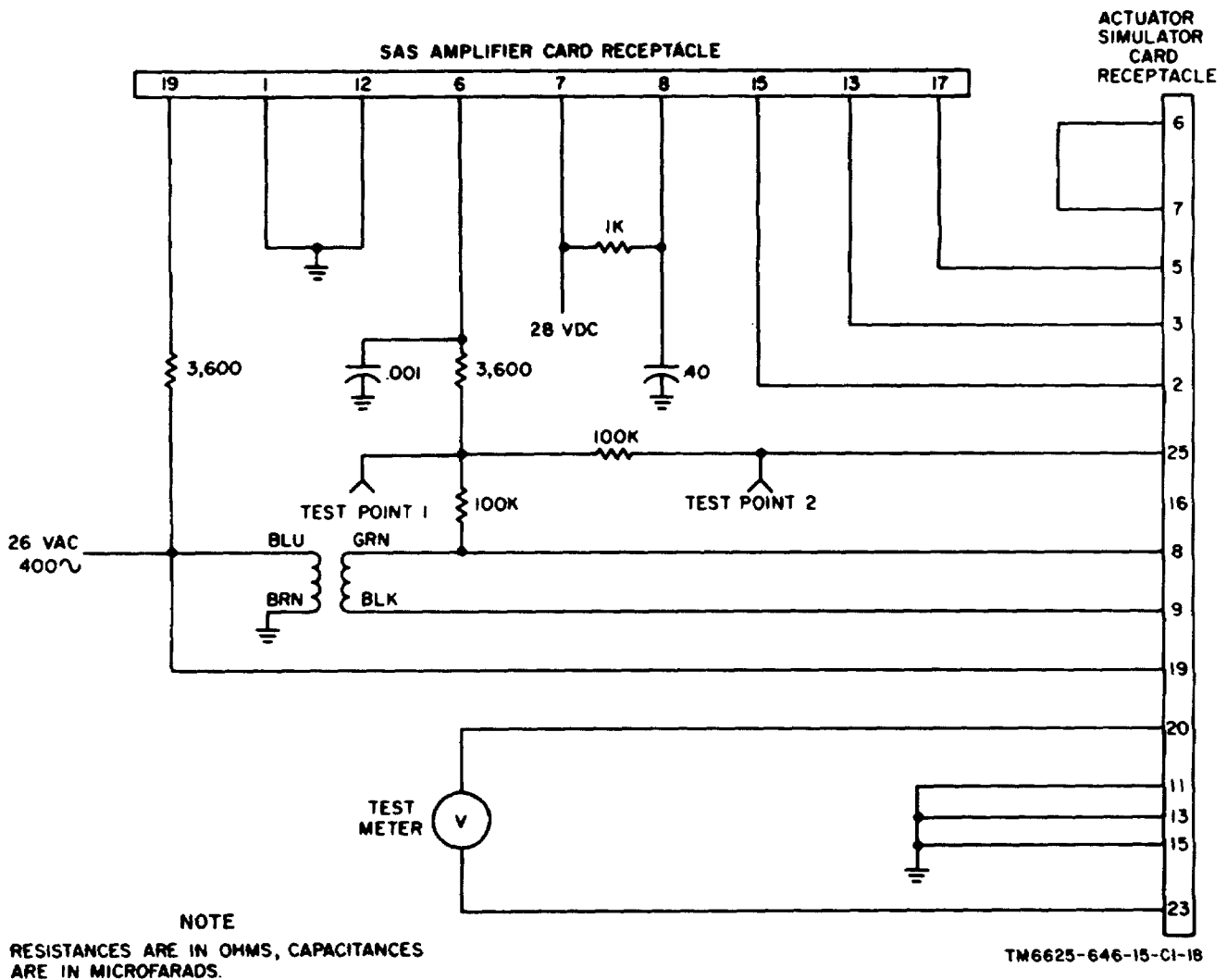

Figure 6-6. Actuator-simulator card, test setup.

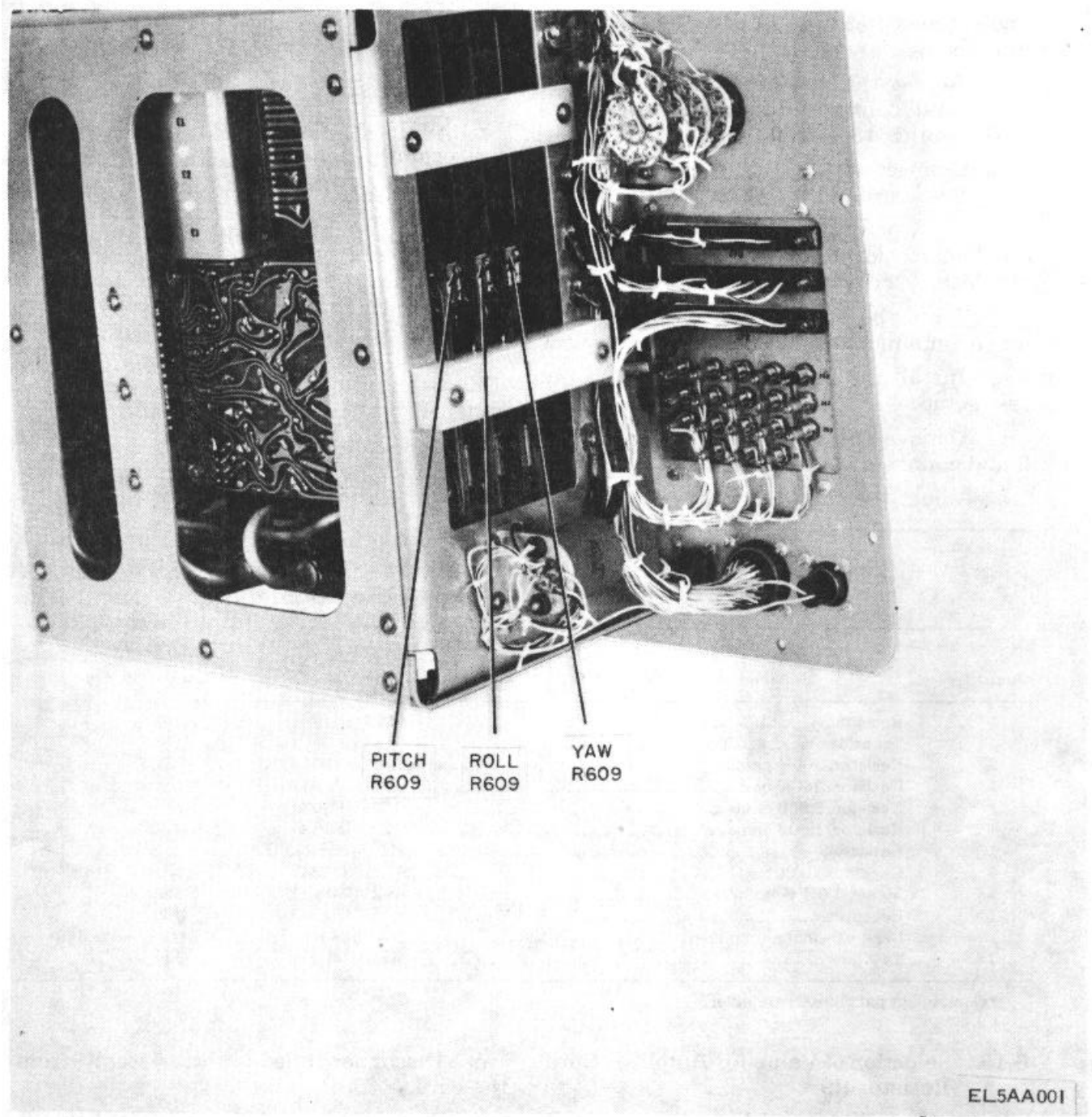

Figure 6-7. Balance resistors location.

component, other than those in the demodulator and output emitter follower circuits, is replaced, the filter and meter rectifier circuits must be calibrated to determine if capacitor C607 or resistor R648 must be a different value. Using the material listed in table 6-5, fabricate

the test setup as shown in figure 6-6. Calibrate the filter and meter rectifier circuits as follows:

- a. Disconnect capacitor C607 and resistor R648 from the actuator simulator card.
- b. Install the actuator simulator card in

the test setup.

- c. Adjust the capacitor decade to 0.25 μ f and connect it to the card in place of capacitor C607.
- d. Adjust the resistor decade to 6,200 ohms and connect it to the card in place of resistor R648.
- e. Connect the ac vtm between test point 2 and ground.
- f. Apply power to the test setup and allow one minute for the circuits of the card to stabilize.
- g. Adjust balance resistor R609 (fig. 6-7) for a minimum indication on the vtm.
- h. Install the SAS amplifier card in the test setup.
- i. Remove the vtm lead from test point 2 and connect it to test point 1.
- j. Adjust the capacitor decade for a minimum

indication on the vtm. Then adjust the capacitor decade to the nearest standard value given for capacitor C607 in appendix IV (23, fig. 9-2).

- k. Remove the vtm lead from test point 1 and connect it to test point 2.
- l. Adjust the resistor decade until the test meter indication agrees with the vtm indication within 0.05 volts. Adjust the resistor decade to the nearest standard value given for resistor R648 in appendix IV (1, fig. 9-2).
- m. Remove power from the test setup. Disconnect the vtm and remove the two cards.
- n. Select a capacitor of the value determined in j above and install it in place of C607.
- o. Select a resistor of the value determined in l above and install it in place of R648.

Table 6-5. Material Required to Fabricate Test Setup

Quantity	Nomenclature	Part No.	Reference designation of equivalent part in test set
1	Receptacle.....	4527	J63
1	Transformer.....	DO-T23	T301
2	Resistor, 100K ohms.....	RC20GF104J	R205
1	Resistor, 330K ohms.....	RC20GF334J	none*
1	Resistor, 3,600 ohms.....	RC20GF362J	none
1	Resistor, 1,000 ohms.....	RC20GF102J	R302
1	Capacitor, 40 μ f.....	109D406C2030F2	none*
1	Capacitor, 0.001 μ f.....	96P10201S4	none
1	Meter, 1-0-1 volt.....	A02VS302-1	none
1	Receptacle.....	BACC45HM3	J69
1	Card assembly, amplifier.....	114E3049-47	installed in J69
2	Test jack.....	MS16108-2	J1

*Component part of SAS amplifier.

6-16. Selection of Value for Amplifier Card Resistor R9

When an amplifier card has been repaired, gain control resistor R9 must be checked. Its value must insure that the output signal level does not exceed the required upper limit. Proceed as follows:

- a. Connect the TS-1894/ASM to primary power. (Refer to operating instructions for the TS-1894/ASM.)

- b. Disconnect one lead of resistor R9 from the card.
- c. Plug the card into the AMPLIFIER CARD TESTER receptacle, component-side down.
- d. Connect a decade resistor to the card in place of resistor R9. Adjust the decade resistor to 0.
- e. Turn the FUNCTION switch to AMPL

OUP.T. Operate the 115V 400~POWER switch to on (up) position Allow a 20-minute warmup.

NOTE

When an amplifier card is plugged into the TS-1894/ASM, a FUNCTION meter deviation maybe noted. If the null position is more than two units from zero, the card is defective. Each division on the meter scale equals two units.

f. Hold the CARD TEST SIGNAL switch at L. Adjust the decade resistor until the FUNCTION meter

indicates 10 units to the left of null. Record the resistance on the decade resistor.

g. Hold the CARD TEST SIGNAL switch at R and adjust the decade resistor until the FUNCTION meter indicates 10 units to the right of null. Record the resistance on the decade resistor.

h. Disconnect the decade resistor. Install a resistor having a standard value closest to the average of the two values recorded in *f* and *g* above for resistor R9. The indicated resistance should not be more than 68 ohms.

i. Repeat *f* and *g* above to insure that the resistor installed meets the test requirements.

(Next printed page is 65)

**SECTION VII
DEPOT OVERHAUL STANDARDS**

7-1. Applicability of Depot Overhaul Standards

Test set TS-1894/ASM must be tested thoroughly after rebuild or repair to insure it meets adequate performance standards for return to stock or reissue. Use the tests in this section to measure the performance of the repaired test set. It is mandatory that repaired equipment to be reissued, or returned to stock for reissue, meet all performance standards outlines in this section.

7-2. Applicable References

a. *Repair Standards.* Applicable procedures of the depot performing this test and the general standards for

repaired electronic equipment in TM SIG 355-1, TB SIG 355-2, and TB SIG 355-3 form a part of the requirements for testing this equipment.

b. *Technical Publications.* No other publication is applicable to this equipment.

c. *Modification Work Orders.* Perform all modification work orders applicable to the TS-1894/ASM before making the tests specified. DA Pam 310-7 lists all applicable MWO's.

7-3. Test Facilities Required

The following items are required for depot testing:

Item	NATIONAL stock No. or part No.	Technical manual
Ac power supply	W5MT3A or equiv	
Dc power supply	HWP712B or equiv	
Decade resistance.....	AN/URM-2 or equiv	
Variable resistor 1,000 ohms	T10A1000 or equiv	
Electronic voltmeter ME-30 (*)/U (vtvm).....	6625-00-643-1670	TM 11-6625-320-12
Manometer.....	34BFZ-20 (Meriam)	
Multimeter TS-352B/U.....	6625-00-553-0142	TM 11-6625-366-15
Dc voltmeter, 0 to 15 volts	341 or equiv	

7-4. Preliminary Procedures

a. Remove the front panel attaching screws. Remove the panel-chassis from the case.

b. Check that the controls are positioned as follows:

Control	Function
FUNCTION switch.....	AC PWR
ASE MODE switch	OFF
115V 400 ~ POWER switch	Off (down)
PUMP switch.....	Off (down)
Adapter switch.....	POS-B
AXES METERS READ switch	OPEN LOOP
PEDAL POT control	Centered

c. Connect power cable A02VS309-2 between receptacle J61 115V 60 ~ and a 115-volt 60cycle power source.

d. Connect power cable A02VS309-3 between receptacle J62 115V 400 ~ and a 115volt 400-cycle power source.

7-5. Ac Power Supply Circuit and Meter Rectifier Circuit Test

a. Connect the vtvm between DEM/MOD CARD TESTER receptacle pins 12 (gnd) and 18. Adjust the vtvm to indicate ac volts.

b. Set the 115V 400- POWER switch to on

(up) position. The vtvm should indicate between 24.5 and 27.5 volts. The FUNCTION meter should indicate between +8 and +12 volts.

c. Set the 115V 400 ~ POWER switch to off (down) position.

d. Disconnect the vtvm.

e. If any indication is not as specified, take corrective action and repeat the applicable steps.

7-6. Dc Power Supply Circuit Test

a. Turn the FUNCTION switch to DC PWR.

b. Connect the multimeter between AMPLIFIER CARD TESTER receptacle pin 7 (positive) and 12. Adjust the multimeter to measure 30 volts dc.

c. Set the 115V 400 ~ POWER switch to on (up) position. The FUNCTION meter should indicate between +8 and +12. The multimeter should indicate between 25 and 29 volts.

d. Increase the 400-cycle supply voltage to 120 volts. The multimeter indication should not change.

NOTE

If the 400-cycle supply is not adjustable, connect power to the test set through an autotransformer for this test.

WARNING

Be careful when using the autotransformer or power supply. Above 45 volts its output is dangerous to life.

e. Set the 115V 400, POWER switch to off (down) position.

f. Disconnect the multimeter.

g. If any indication is not as specified, take corrective action and repeat the applicable steps.

7-7. Metering Circuits Tests

a. Remove the amplifier card from TS-1894/ASM receptacle J69.

b. Turn the FUNCTION switch to DC PWR.

c. Connect the dc power supply to TEST 66 CHANGE 4 POINTS A (positive) and C. Adjust the dc supply to 24 volts. The FUNCTION meter should indicate between +7 and +10. Disconnect the dc supply.

d. Turn the FUNCTION switch to AC PWR.

e. Connect the ac power supply to TEST POINTS B and C. Adjust the ac supply to 26 volts. The FUNCTION meter should indicate 0. Disconnect the ac power.

f. Turn the FUNCTION switch to PEDAL POT. EXCITATION.

g. Connect the dc power supply to TEST POINTS j (positive) and f. Adjust the dc supply for +40 volts. The FUNCTION meter should indicate between +8 and +12.

WARNING

Be careful when using the dc power supply. Above 45 volts its output is dangerous to life.

h. Turn the FUNCTION switch to PEDAL POT. OUTPUT.

i. Connect the multimeter between TEST POINTS h (positive) and C. Adjust the multimeter to measure 30 volts dc.

j. Turn the PEDAL POT. control fully counterclockwise. The FUNCTION meter should indicate a minimum of +16.

k. Turn the PEDAL POT. control clockwise until the FUNCTION meter indicates +10. The multimeter should indicate between 9 and 11 volts.

l. Turn the PEDAL POT. control clockwise until the FUNCTION meter indicates 0. The multimeter should indicate 0.

m. Reverse the multimeter connections at TEST POINTS C and h.

n. Turn the PEDAL POT. control fully clockwise. The FUNCTION meter should indicate a minimum of -16.

o. Turn the PEDAL POT. control counterclockwise until the FUNCTION meter indicates -10. The multimeter should indicate between 9 and 11 volts.

p. Turn the FUNCTION switch to INTLK.

q. Connect the dc power supply to TEST

POINTS D (positive) and C. Adjust the dc supply until the FUNCTION meter indicates +10. The dc supply meter should indicate between 24 and 36 volts. Disconnect the dc supply.

r. Turn the FUNCTION switch to DEM OUTPT.

s. Connect the dc power supply to pins 15 (positive) and 17 of amplifier card receptacle J69. Adjust the power supply to 2.1 volts. The FUNCTION meter should indicate between +8 and +12.

t. Turn the FUNCTION switch to AMPL OUPPT.

u. Connect the dc power supply to pins 17 (positive) and 15 of the AMPLIFIER CARD TESTER receptacle. Adjust the dc supply until the FUNCTION meter indicates +10. The dc supply meter should indicate between 3.04 and 4.56 volts.

v. Turn the FUNCTION switch to YAW FEEDBACK.

w. Connect the ac power supply to TEST POINTS M (neutral) and P (line phase).

x. Set the 115V 400 ~ POWER switch to on (up) position.

y. Adjust the ac supply until the FUNCTION meter indicates +10. The ac supply meter should indicate between 2 and 3 volts.

z. Turn the FUNCTION switch to ROLL FEEDBACK. Connect the ac power supply to TEST POINTS X (neutral) and V (line phase). Adjust the ac supply until the FUNCTION meter indicates +10. The ac supply meter should indicate between 2 and 3 volts. Disconnect the power supply.

aa. Turn the FUNCTION switch to PITCH FEEDBACK.

ab. Connect the ac power supply to TEST POINTS e (neutral) and c (line phase). Adjust the ac supply until the FUNCTION meter indicates +10. The ac supply meter should indicate between 2 and 3 volts. Disconnect the power supply.

ac. Turn the FUNCTION switch to SEC FEEDBACK.

ad. Connect the ac power supply to TEST POINTS q (neutral) and k (line phase). Adjust the ac supply until

the FUNCTION meter indicates +10. The ac supply meter should indicate between 2 and 3 volts.

ae. Disconnect the power supply and test leads.

af. If any indication is not as specified, take corrective action and repeat the applicable steps.

ag. Reinstall the amplifier card in receptacle J69.

7-8. Actuator Simulator Test

a. *Preliminary Procedures.*

(1) Fabricate a test setup (fig. 7-1).

(2) Remove the amplifier card from receptacle J69.

(3) Connect the dc power supply through an isolation transformer to the proper power source.

(4) Connect the ac power supply to 115volt 400-cycle power.

(5) Connect jumpers between pins 3 and 17 of receptacles J63, J64 and J65.

(6) Operate the AXES METERS READ switch to OPEN LOOP.

NOTE

Before recording meter indications, wait approximately 30 seconds for the actuator-simulator card circuits to stabilize. Do this when power is initially applied and when input level is varied.

b. *Roll Axis Actuator Simulator Circuit.*

(1) Connect the ac power supply to TEST POINTS V (line phase) and X.

(2) Connect the test setup to TEST POINTS T and R (fig. 7-1).

(3) Connect the vtvm between TEST POINTS C (ground) and W.

(4) Adjust the dc supply for a 12-volt output.

(5) Set the 115V 400 ~ POWER switch to on (up) position.

(6) Adjust the test setup variable resistor

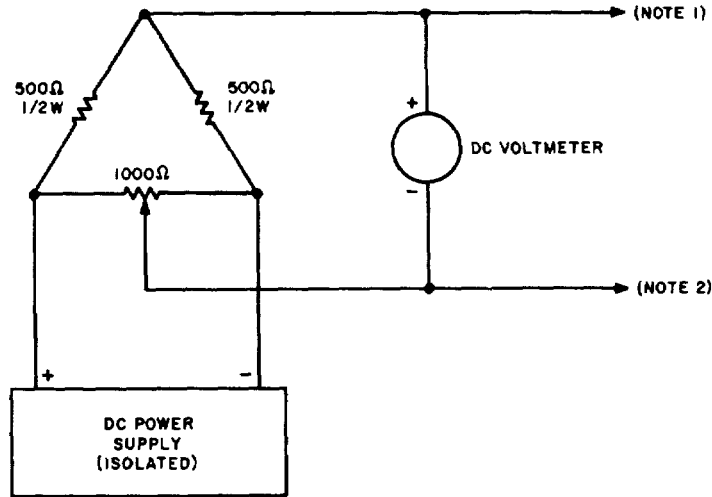

NOTES:
1 CONNECT AS FOLLOWS:

AXIS	TP
ROLL	R
PITCH	Y
YAW	H

2 CONNECT AS FOLLOWS:

AXIS	TP
ROLL	T
PITCH	Q
YAW	K

TM6625-646-15-CI-17

Figure 7-1. Test device, simulated torque motor voltages.

until the dc voltmeter indicates +5. The ROLL AXIS meter should indicate between +4.5 and +5.5 volts.

(7) Adjust the test setup variable resistor until the dc voltmeter indicates 0.

(8) Adjust the ac supply for a 2.5-volt output.

(9) Set the AXES METERS READ switch to CLOSED LOOP.

NOTE

The ROLL AXIS meter may indicate off scale (hardover). Allow 30 seconds for the circuits to stabilize.

(10) Check that the ROLL AXIS meter indicates 0 ± 1 scale division. If it does not, adjust

resistor R609 (fig. 6-7) on the roll actuator simulator card for 0 on the meter.

(11) Adjust the test setup variable resistor until the dc voltmeter indicates 0.1 volt. The ROLL AXIS meter should indicate a minimum of +1 volt. The vtvm should indicate a minimum of +1 volt.

(12) Adjust the test setup variable resistor until the dc voltmeter indicates 0.

(13) Reverse the test setup connections at TEST POINTS R and T.

(14) Adjust the test setup variable resistor until the dc voltmeter indicates 0.1 volt. The ROLL AXIS meter should indicate a minimum of -1 volt. The vtvm should indicate a minimum of 1 volt.

(15) Adjust the test setup variable resistor until the ROLL AXIS meter indicates .5 in either direction. The vtvm should indicate between 0.45 and 0.55 volt.

(16) Adjust the test setup variable resistor until the dc voltmeter indicates 0.

(17) Set the 115V 400- POWER switch to off (down) position. Disconnect the test connections from TEST POINTS R, T, V, W, and X.

(18) If any indication is not as specified, take corrective action and repeat the applicable steps.

(19) Set the AXES METERS READ switch to OPEN LOOP.

c. Pitch Axis Actuator Simulator Circuit.

(1) Connect the ac power supply to TEST POINTS c (line phase) and e.

(2) Connect the test setup to TEST POINTS a and Y. (fig. 7-1).

(3) Connect the vtvm between TEST POINTS C (ground) and d.

(4) Adjust the dc power supply for a 12-volt output.

(5) Set the 115V 400- POWER switch to on (up) position.

(6) Adjust the test setup variable resistor until the dc voltmeter indicates +5. The PITCH AXIS meter should indicate between +4.5 and +5.5 volts.

(7) Adjust the test setup variable resistor until the dc voltmeter indicates 0.

(8) Adjust the ac supply for a 2.5-volt output.

(9) Set the AXES METERS READ switch to CLOSED LOOP.

NOTE

The PITCH AXIS meter may indicate off scale (hardover). Allow 30 seconds for the circuits to stabilize.

(10) Check that the PITCH AXIS meter indicates 0 ± 1 scale division. If it does not, adjust resistor R609 (fig. 6-7) on the pitch actuator simulator card for 0 on the meter.

(11) Adjust the test setup variable resistor until the dc voltmeter indicates 0.1 volt. The PITCH AXIS

meter should indicate a minimum of +1 volt. The vtvm should indicate a minimum of 1 volt.

(12) Adjust the test setup variable resistor until the dc voltmeter indicates 0.

(13) Reverse the test setup connections at TEST POINTS Y and a.

(14) Adjust the test setup variable resistor until the dc voltmeter indicates 0.1 volt. The PITCH AXIS meter should indicate a minimum of -1 volt. The vtvm should indicate a minimum of 1 volt.

(15) Adjust the test setup variable resistor until the PITCH AXIS meter indicates .5 in either direction. The vtvm should indicate between 0.45 and 0.55 volt.

(16) Adjust the test setup variable resistor until the dc voltmeter indicates 0.

(17) Set the 115V 400 ~ POWER switch to off (down) position. Disconnect the test connections from TEST POINTS Y, a, c, d, and e.

(18) If any indication is not as specified, take corrective action and repeat the applicable steps.

(19) Operate the AXES METERS READ switch to OPEN LOOP.

d. Yaw Axis Actuator Simulator Circuit.

(1) Connect the ac power supply to TEST POINTS M and P (line phase).

(2) Connect the test setup to TEST POINTS K and H (fig. 7-1).

(3) Connect the vtvm between TEST POINTS C (ground) and L.

(4) Adjust the dc power supply for a 12-volt output.

(5) Set the 115V 400 ~ POWER switch to on (up) position.

(6) Adjust the test setup variable resistor until the dc voltmeter indicates +5. The YAW AXIS meter should indicate between -4.5 and -5.5 volts.

(7) Adjust the test setup variable resistor until the dc voltmeter indicates 0.

(8) Adjust the ac supply for a 2.5-volt output.

(9) Set the AXES METERS READ switch to CLOSED LOOP.

NOTE

The YAW AXIS meter may indicate off scale (hardover). Allow 30 seconds for the circuits to stabilize.

(10) Check that the YAW AXIS meter indicates 0 ± 1 scale division. If it does not, adjust resistor R609 (fig. 6-7) on the yaw actuator-simulator card for 0 on the meter.

(11) Adjust the test setup variable resistor until the dc voltmeter indicates 0.1 volt. The YAW AXIS meter should indicate a minimum of -1 volt. The vtvm should indicate a minimum of 1 volt.

(12) Adjust the test setup variable resistor until the dc voltmeter indicates 0.

(13) Reverse the test setup connections at TEST POINTS H and K.

(14) Adjust the test setup variable resistor until the dc voltmeter indicates 0.1 volt. The YAW AXIS meter should indicate a minimum of +1 volt. The vtvm should indicate a minimum of 1 volt.

(15) Adjust the test setup variable resistor until the YAW AXIS meter indicates .5 in either direction. The vtvm should indicate between 0.45 and 0.55.

(16) Adjust the test setup variable resistor until the dc voltmeter indicates 0.

(17) Set the 115V 400 ~ POWER switch of off (down) position. Disconnect all the- test connections.

(18) If any indication is not as specified, take corrective action and repeat the applicable steps.

(19) Operate the AXES METERS READ switch to OPEN LOOP.

(20) Reinstall the amplifier card in receptacle J69.

7-9. Internal Amplifier Card Circuit Test

a. Connect a jumper between DEM/MOD CARD TESTER receptacle pin 16 and AMPLIFIER CARD TESTER receptacle pin 6.

b. Turn the FUNCTION switch to DEM OUP.T.

c. Set the 115V 400 ~ POWER switch to on (up) position. Allow 15 minutes for warmup. The FUNCTION meter should indicate no more than 1 scale division.

d. Hold the CARD TEST SIGNAL switch at L. The FUNCTION meter should indicate between +8 and +15.

e. Hold the CARD TEST SIGNAL switch to R. The FUNCTION meter should indicate between -8 and - 15.

f. Release the CARD TEST SIGNAL switch.

g. Disconnect the jumper.

h. If any indication is not as specified, take corrective action and repeat the applicable steps.

7-10. External AMPLIFIER CARD TESTER Circuit Test

a. Remove the amplifier card from receptacle J69. Install it in AMPLIFIER CARD TESTER receptacle J71.

b. Turn the FUNCTION switch to AMPL OUP.T.

c. Set the 115V 400 ~ POWER switch to on (up) position. Allow 15 minutes for warmup.

d. Hold the CARD TEST SIGNAL switch at L. The FUNCTION meter should indicate between -3 and -7.

e. Hold the CARD TEST SIGNAL switch at R. The FUNCTION meter should indicate between +3 and +7.

f. Remove the amplifier card from receptacle J71. Install it in receptacle J69.

g. If any indication is not as specified, take corrective action and repeat the applicable steps.

7-11. External DEM/MOD CARD TESTER Circuit Test

a. Check for 98K to 102K ohms between pins 1 and 7 of receptacle J70.

b. Check for 2,040 to 3,060 ohms between pins 3 and 12.

c. Check for 57,820 to 60,180 ohms between pins 3 and 8.

d. Check for 0 ohms between pins 2, 4, 5, and 7; between ground and pin 17. Check for 0 ohms between ground and pin 9.

- e. Set the 115V 400 ~ POWER switch to on (up) position.
- f. Check for 24 to 28 volts ac between pins 12 and 18.
- g. Set the 115V 400 ~ POWER switch to off (down) position.
- h. If any indication is not as specified, take corrective action and repeat the applicable steps.

7-12. Half-Gain Circuits Test

- a. Connect a jumper between TEST POINTS E and G.
- b. Connect a 200-ohm, 5-watt resistor between TEST POINTS A and C.
- c. Set the 115V 400 ~ POWER switch to up (on) position. Check that the FULL GAIN indicator is on.
- d. Press the HALF-GAIN switch. Check for 28 to 36 volts dc at TEST POINTS F.
- e. Release the HALF-GAIN switch. Disconnect the jumper and resistor.
- f. If any indication is not as specified, take corrective action and repeat the applicable steps.

7-13. Pneumatic Components Test

- a. *Airspeed.*
 - (1) Connect the manometer to the P and S air connections on the TS-1894/ASM. Use the hose assemblies furnished.
 - (2) Set the PUMP switch to on (up) position.
 - (3) Adjust AIRSPEED to the indications in table 7-1. The manometer pressures should be as specified in the table.
 - (4) Set the PUMP switch to off (down) position.
 - (5) Disconnect the hose assemblies.
 - (6) If any indication is not as specified, take corrective action and repeat the applicable steps.

Table 7-1. AIRSPEED Indicator Test

AIRSPEED indication (knots)	Manometer pressure (inches)
80	3.99 to 4.41
150	13.6 to 15.0
0	0

b. Differential Pressure.

- (1) Connect the manometer to the L and R air connections on the TS-1894/ASM. Use the hose assemblies furnished.
- (2) Set the PUMP switch to on (up) position.
- (3) Adjust the DIFF. PRESSURE to the indications in table 7-2. The manometer pressures should be as specified in the table.
- (4) Set the PUMP switch to its off (down) position.
- (5) Disconnect the hose assemblies.
- (6) If any indication is not as specified, take corrective action and repeat the applicable steps.

Table 7-2. DIFF. PRESSURE Indicator Test

DIFF. PRESSURE Indication (inches)	Manometer pressure (inches)
3.5R	3.33 to 3.67
14R	13.3 to 14.7
3.5L	3.33 to 3.67
14L	13.3 to 14.7
0	0

7-14. Adapter Circuits Test

- a. Turn the ROLL GYRO SIMULATOR switch to OFF. Turn the GAIN SWITCH to AIR.
- b. Check for 0 ohm between corresponding pins of J101 and P101 except pins j, h, f, and B.
- c. Check for 0 ohm between J101 pins j and f and TB101 terminals 6, 7, and 10. Check for 0 ohm between J101-h and TB101-13. Check for 0 ohm between J101-B and TB101-12.
- d. Connect the ac power supply between J101 pins p and C (ground). Adjust the ac supply to 26 volts. Check for 12.38 to 13.64 volts ac between J101 pins h and C. Use the vtm.
- e. Connect the vtm between J101 pins f and j.
- f. Turn the ROLL GYRO SIMULATOR switch R LIM and then to L LIM. The vtm should indicate between 2.71 and 2.99 volts ac.
- g. Turn the ROLL GYRO SIMULATOR switch to L ROLL and then to R ROLL. The

vtvm should indicate between 606 and 679 mV ac.

h. Disconnect the vtvvm.

i. If any indication is not as specified, take corrective action and repeat the applicable steps.

7-15. Stopping Procedures

After calibration, evaluation, and corrective action, set all power switches to off (down) position. Disconnect all test leads and power cables. Stow the test leads adapter, and power cables in the cover of the TS-1894/ASM.

(Next printed page is 75)

APPENDIX I REFERENCES

Following is a list of references applicable and available to the operator and repair personnel for the TS-1894/ASM.

DA Pam 310-4	Index of Technical Manuals, Technical Bulletins, Supply Manuals (types 7, 8, and 9), Supply Bulletins, and Lubrication Orders.
DA Pam 310-7	Index of Modification Work Orders.
FM 10-16	General Repair for Canvas and Webbing.
TB SIG 355-1	Depot Inspection Standard for Repaired Signal Equipment.
TB SIG 355-2	Depot Inspection Standard for Refinishing Repaired Signal Equipment.
TB SIG 355-3	Depot Inspection Standard for Moisture and Fungus Resistant Treatment.
TB 43-0118	Field Instructions for Painting and Preserving Electronics Command Equipment Including Camouflage Pattern Painting of Electrical Equipment Shelters.
TM 11-1680-201-35	Direct Support, General Support, and Depot Maintenance Manual Amplifiers, Stability Augmentation System (Parts No. 114E3030-40, 114E3030-42, 114E3030-43, 114E3030-47, and 114E3030-49) for Army Model CH-47, CH-47B, and CH-47C Helicopters.
TM 11-6625-320-12	Operator and Organizational Maintenance Manual: Voltmeter, Meter ME-30A/U and Voltmeters, Electronic ME-30B/U, ME-30C/U, and ME-30E/U.
TM 11-6625-366-15	Operator's, Organizational, DS, GS, and Depot Maintenance Manual: Multimeter TS-352B/U.
TM 11-6625-613-12	Organizational Maintenance Manual: Simulator, Aircraft Displacement AN/ASM-120.
TM 11-6625-646-24P	Organizational and General Support Maintenance Repair Parts and Special Tools List (Including Depot Maintenance Repair Parts and Special Tools): Test Set, Stabilization Equipment TS-1894/ASM.
TM 38750	The Army Maintenance Management System (TAMMS).
TM 55-1520-209-20-1 & -2	Organizational Maintenance Manual: Army Model CH-47A Helicopter.
TM 55-1520-227-20-1 & -2	Organizational Maintenance Manual: Army Model CH-47B and CH-47C Helicopters.

(Next printed page is 79)

Change 4 75/(76 blank)

APPENDIX III MAINTENANCE ALLOCATION

Section I. INTRODUCTION

A3-1. General.

This appendix provides a summary of the maintenance operations for TS-1894/ASM. It authorizes categories of maintenance for specific maintenance functions on repairable items and components and the tools and equipment required to perform each function. This appendix may be used as an aid in planning maintenance operations.

A3-2. Maintenance Function.

Maintenance functions will be limited to and defined as follows:

a. Inspect. To determine the serviceability of an item by comparing its physical, mechanical, and/or electrical characteristics with established standards through examination.

b. Test. To verify serviceability and to detect incipient failure by measuring the mechanical or electrical characteristics of an item and comparing those characteristics with prescribed standards.

c. Service. Operations required periodically to keep an item in proper operating condition, i.e., to clean (decontaminate), to preserve, to drain, to paint, or to replenish fuel, lubricants, hydraulic fluids, or compressed air supplies.

d. Adjust. To maintain, within prescribed limits, by bringing into proper or exact position, or by setting the operating characteristics to the specified parameters.

e. Align. To adjust specified variable elements of an item to bring about optimum or desired performance.

f. Calibrate. To determine and cause corrections to be made or to be adjusted on instruments or test measuring and diagnostic equipments used in precision measurement. Consists of comparisons of two instruments, one of which is a certified standard of known accuracy, to detect and adjust any discrepancy in the accuracy of the instrument being compared.

g. Install. The act of emplacing, seating, or fixing into position an item, part, module (component or assembly) in a manner to allow the proper functioning of the equipment or system.

h. Replace. The act of substituting a serviceable like type part, subassembly, or module (component or assembly) for an unserviceable counterpart.

i. Repair. The application of maintenance services (inspect, test, service, adjust, align, calibrate,

replace) or other maintenance actions (welding, grinding, riveting, straightening, facing, remachining, or resurfacing) to restore serviceability to an item by correcting specific damage, fault, malfunction, or failure in a part, subassembly, module (component or assembly), end item, or system.

j. Overhaul. That maintenance effort (service/action) necessary to restore an item to a completely serviceable/operational condition as prescribed by maintenance standards (i.e., DMWR) in appropriate technical publications. Overhaul is normally the highest degree of maintenance performed by the Army. Overhaul does not normally return an item to like new condition.

k. Rebuild. Consists of those services/actions necessary for the restoration of unserviceable equipment to a like new condition in accordance with original manufacturing standards. Rebuild is the highest degree of materiel maintenance applied to Army equipment. The rebuild operation includes the act of returning to zero those age measurements (hours, miles, etc.) considered in classifying Army equipments/components.

A3-3. Column Entries.

a. Column 1, Group Number. Column 1 lists group numbers, the purpose of which is to identify components, assemblies, subassemblies, and modules with the next higher assembly.

b. Column 2, Component Assembly. Column 2 contains the noun names of components, assemblies, subassemblies, and modules for which maintenance is authorized.

c. Column 3, Maintenance Functions. Column 3 lists the functions to be performed or the item listed in column 2. When items are listed without maintenance functions, it is solely for purpose of having the group numbers in the MAC and RPSTL coincide.

d. Column 4, Maintenance Category. Column 4 specifies, by the listing of a "worktime" figure in the appropriate subcolumn(s), the lowest level of maintenance authorized to perform the function listed in column 3. This figure represents the active time required to perform that maintenance function at the indicated category of maintenance. If the number or complexity of the tasks within the

listed maintenance function vary at different maintenance categories, appropriate "worktime" figures will be shown for each category. The number of task-hours specified by the "worktime" figure represents the average time required to restore an item (assembly, subassembly, component, module, end item or system) to a serviceable condition under typical field operating conditions. This time includes preparation time, troubleshooting time, and quality assurance/quality control time in addition to the time required to perform the specific tasks identified for the maintenance functions authorized in the maintenance allocation chart. Subcolumns of column 4 are as follows:

- C - Operator/Crew
- O - Organizational
- F - Direct Support
- H - General Support
- D - Depot

e. Column 5, Tools and Equipment. Column 5 specifies by code, those common tool sets (not individual tools) and special tools, test, and support equipment required to perform the designated function.

f. Column 6, Remarks. Column 6 contains an alphabetic code which leads to the remark in section IV, Remarks, which is pertinent to the item opposite the particular code.

A3-4. Tool and Test Equipment Requirements (Sect III).

a. Tool or Test Equipment Reference Code. The numbers in this column coincide with the numbers used in the tools and equipment column of the MAC. The numbers indicate the applicable tool or test equipment for the maintenance functions.

b. Maintenance Category. The codes in this column indicate the maintenance category allocated the tool or test equipment.

c. Nomenclature. This column lists the noun name and nomenclature of the tools and test equipment required to perform the maintenance functions.

d. National/NATO Stock Number. This column lists the National/NATO stock number of the specific tool or test equipment.

e. Tool Number. This column lists the manufacturer's part number of the tool followed by the Federal Supply Code for manufacturers (5-digit) in parentheses.

A3-5. Remarks (Sect IV).

a. Reference Code. This code refers to the appropriate item in section II, column 6.

b. Remarks. This column provides the required explanatory information necessary to clarify items appearing in section II.

**SECTION II MAINTENANCE ALLOCATION CHART
FOR
TEST SET, STABILIZATION EQUIPMENT TS-1894/ASM**

(1) GROUP NUMBER	(2) COMPONENT/ ASSEMBLY	(3) MAINTENANCE FUNCTION	(4) MAINTENANCE CATEGORY					(5) TOOLS AND EQUIP	(6) REMARKS
			C	O	F	H	D		
00	TEST SET, STABILIZATION EQUIPMENT TS-1894/ASM	Inspect Test Service Replace Repair Repair		0.2 0.2 0.3 0.3				1 1 1 2 thru 14 2 thru 15	A B
01	CASE, TEST SET 120 HIFS (94637)	Inspect Service Repair		0.1 0.3			12.0	1 7	
02	BOX ASSEMBLY, ADAPTER 114 V3058-1 (77272)	Inspect Service Replace Repair		0.1 0.1 0.2		1.0		1 1 7	C
0201	CABLE ASSEMBLY 114V3062-1 (77272)	Inspect Test Service Replace Repair		0.2 0.2 0.1 0.2			0.2	1,4 1 1 1,10 thru 14	
0202	COMPONENT ASSEMBLY 114V3060-1 (77272)	Inspect Test Service Replace Repair		0.2 0.1 0.1				1,4 1 7 7	
03	CABLE ASSEMBLY A02 VS309-2 (77272)	Inspect Test Service Replace Repair		0.2 0.2 0.1 0.2				1 1 1,10 thru 14	
04	CABLE ASSEMBLY A02VS309-3 (77272)	Inspect Test Service Replace Repair		0.2 0.2 0.1 0.2				4,7 1 1 2,10 thru 14	
05	CABLE ASSEMBLY A02VS309-1 (77272)	Inspect Test Service Replace Repair		0.2 0.2 0.1 0.2				4,7 1 1 2,10 thru 14	
06	PANEL ASSEMBLY, FRONT 114E5987-7 (77272)	Inspect Test Service Replace Repair		0.2 0.4 0.4				2 thru 9 1 4,7 2 thru 9	
0601	COMPONENT ASSEMBLY, ACTUATOR SIMULATOR CARD A02V3048-2 (77272)	Inspect Test Replace Repair						0.4 0.5 0.4 2 thru 9	
0602	COMPONENT ASSEMBLY AMPLIFIER CARD 114E3049-47 (77272)	Inspect Test Replace Repair						0.4 0.5 0.4 2 thru 9	
0603	COMPONENT ASSEMBLY, CARD A02V3060-2 (77272)	Inspect Test Replace Repair						0.4 0.5 0.4 2 thru 9	

**SECTION II MAINTENANCE ALLOCATION CHART
FOR**

TEST SET, STABILIZATION EQUIPMENT TS-1894/ASM - CONTINUED

(1) GROUP NUMBER	(2) COMPONENT/ ASSEMBLY	(3) MAINTENANCE FUNCTION	(4) MAINTENANCE CATEGORY					(5) TOOLS AND EQUIP	(6) REMARKS
			C	O	F	H	D		
0604	COMPONENT ASSEMBLY CARD A02V3068-1 (77272)	Inspect Test Replace Repair				0.4 0.5 0.4 2.0		2 thru 9 7 2 thru 9	
0605	COMPONENT ASSEMBLY, CARD A02V3064-2 (77272)	Inspect Test Replace Repair				0.4 0.5 0.4 2.0		2 thru 9 7 2 thru 9	
0606	CABLE HARNESS 114E5987-5 (77272)	Inspect Test Service Replace Repair		0.2 0.2 0.1 0.2			0.5	4,7 1 1 2,10 thru 14	
0607	PUMP ASSEMBLY, AIR 0330P110-202 (24123)	Inspect Test Service Replace Repair		0.2 0.2 0.2		0.5		4.7 1 1 4,7	
0608	METERS M1-A02VS302-8 (77272) M2-A02VS302-1 (77272) M3-A0VS302-2 (77272) M4-A02VS302-3 (77272)	Inspect Service Replace		0.2 0.2		0.5		1 1	
0609	GAGES, AIR A02VS301-1 (77272) A02VS301-2 (77272)	Inspect Service Replace		0.2 0.2		0.5		1 1	
0610	MOTOR, PUMP	Inspect Test Replace Repair		0.2 0.2 0.3		1.0		1,3 1 2,3,7	

**SECTION III TOOL AND TEST EQUIPMENT REQUIREMENTS
FOR
TEST SET, STABILIZATION EQUIPMENT TS-1894/ASM**

TOOL OR TEST EQUIPMENT REF CODE	MAINTENANCE CATEGORY	NOMENCLATURE	NATIONAL/NATO STOCK NUMBER	TOOL NUMBER
1	0	TOOL KIT, ELECTRONIC EQUIPMENT TK-10S/G	5180-00-610-8177	
2	H,D	DIFFERENTIAL PRESSURE GAGE 0-15 INCHES OF H ₂ O p/n AOVS301-1		
3	H,D	VOLTMETER, ELECTRONIC ME-30E/U	6625-00-643-1670	
4	H,D	MULTIMETER TS-352B/U*	6625-00-553-0142	
5	H,D	TEST SET, METER TS-682A/GSM-1*	6625-00-669-0747	
6	H,D	TEST SET, TRANSISTOR TS-1836/U	6625-00-893-2628	
7	H,D	TOOL KIT, ELECTRONIC EQUIPMENT TK-100/G	5180-00-605-0079	
8	H,D	AIR SPEED METER, 0-150 KNOTS VERTOL AIRCRAFT p/n AOVS301-2		
9	H,D	DECADE RESISTANCE AN/URM-2*	6625-00-405-6430	
10	O,H	TOOL, CRIMPING	5120-00-856-3732	
11	O,H	TOOL, INSERTION	5120-00-765-3689	
12	O,H	CONTACT REMOVAL KIT	5120-00-765-3688	
13	O,H	POSITIONER, CONTACT	5120-00-083-5020	
14	O,H	POSITIONER, CONTACT	5120-00-083-5019	
15	D	MANOMETER (MERIAM) p/n 34BFZ-20*		
		*OR EQUIVALENT		

SECTION IV. REMARKS

REFERENCE CODE	REMARKS
A	OPERATIONAL TESTS ONLY
B	REPAIR BY REPLACEMENT OF EXTERNAL PARTS AS KNOBS, FUSES, LAMPS AND CABLES.
C	GROUP 02 IS PART OF THE TS-1894/ASM P/N 114E5987-8, BUT NOT PART OF THE TS-1894/ASM P/N 14E5987-4.

APPENDIX IV
ILLUSTRATED PARTS BREAKDOWN

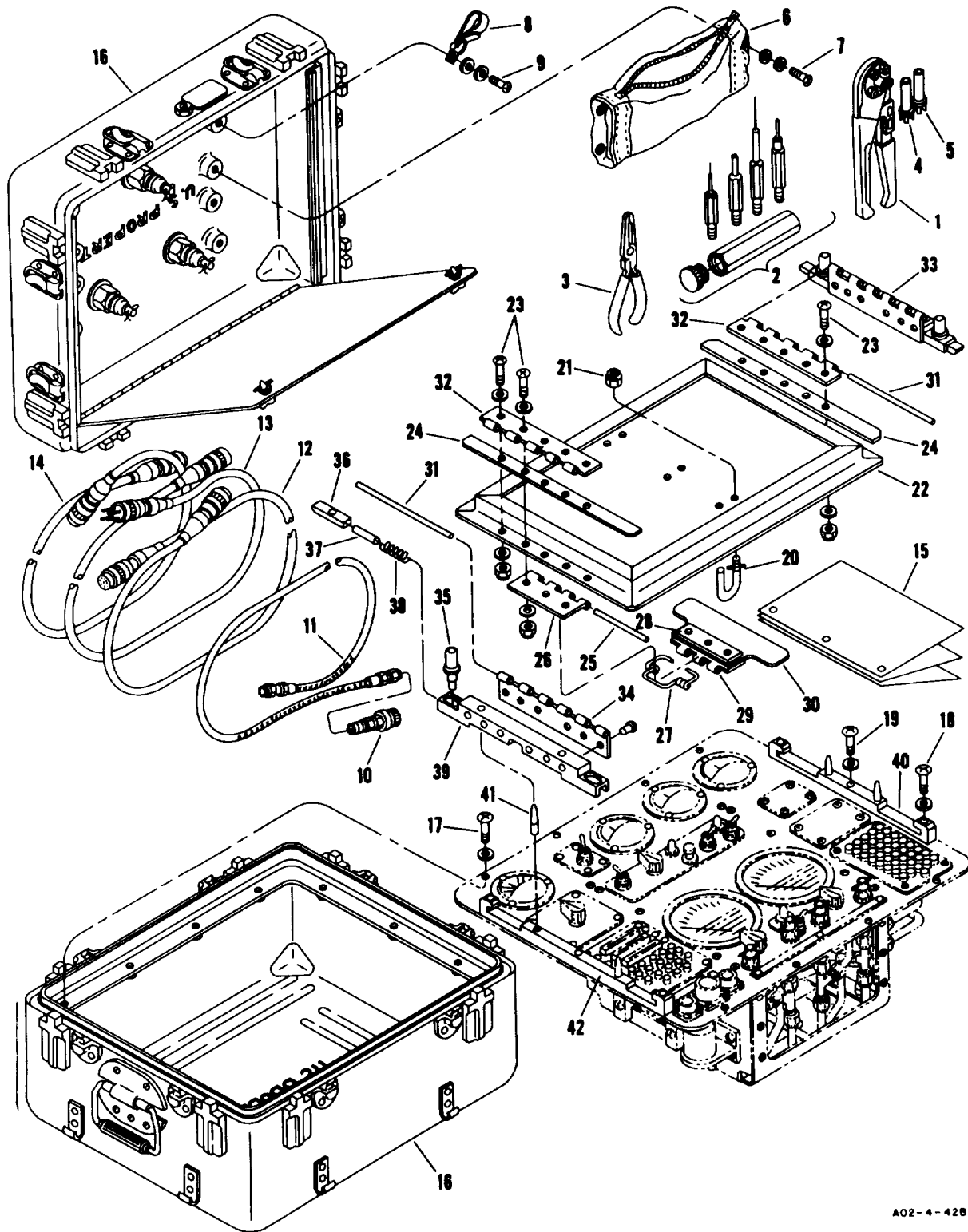

A02-4-428

FIGURE 9-1. SAS BENCH TEST SET, EXPLODED VIEW (SHEET 1)

GROUP ASSEMBLY PARTS LIST

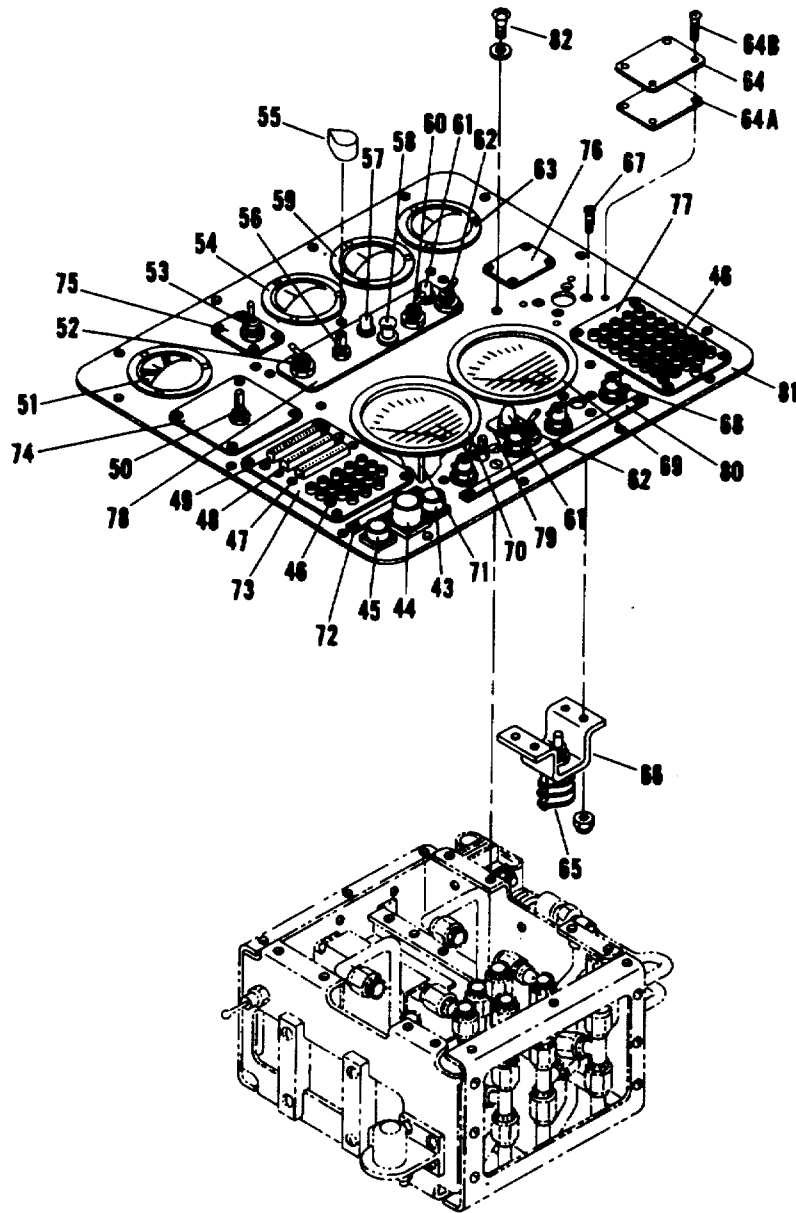

A02-4-428

FIGURE 9-1. SAS BENCH TEST SET, EXPLODED VIEW (SHEET 2)

GROUP ASSEMBLY PARTS LIST

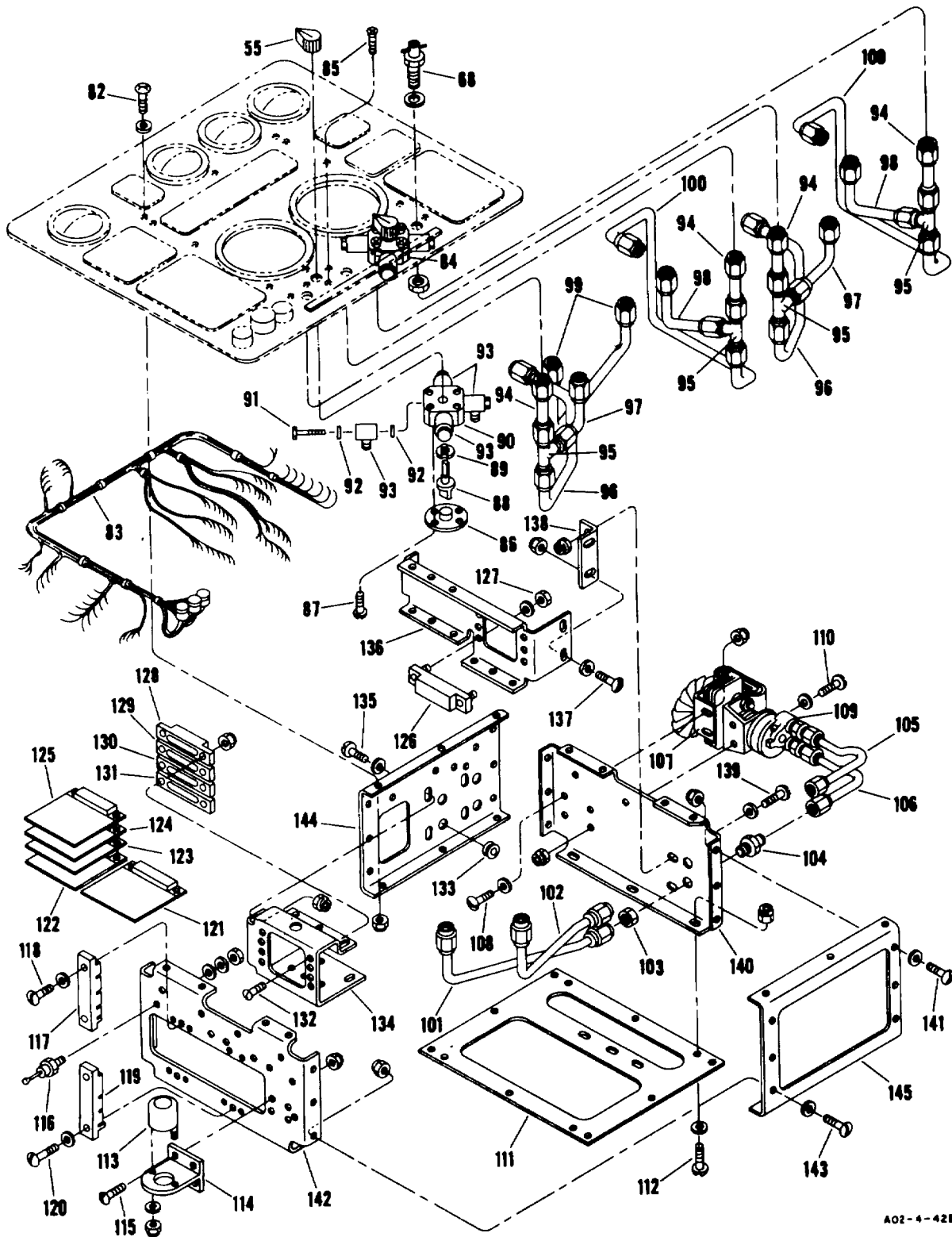

AO2-4-42B

FIGURE 9-1. SAS BENCH TEST SET EXPLODED VIEW(SHEET 3)

GROUP ASSEMBLY PARTS LIST

FIGURE AND INDEX NO.	PART NUMBER	NOMENCLATURE							QTY PER ASSY	USABLE ON CODE
		1	2	3	4	5	6	7		
9-1		TEST SET, SAS BENCH							1	
	-1	. TOOL, CONTACT CRIMPING							1	
	-2	. KIT, CONTACT REMOVAL (77820).....							1	
	-3	. TOOL, CONTACT INSERTION.....							1	
		(77820)								
	-4	. POSITIONER, CONTACT(77820).....							1	
	-5	. POSITIONER, CONTACT(77820).....							1	
	-6	. BAG ASSY, TOOL STORAGE							1	
		ATTACHING PARTS								
	-7	. SCREW							4	
		. WASHER							4	
		. WASHER							4	
	-8	. CLAMP, HARNESS(78553)							4	
		ATTACHING PARTS								
	-9	. SCREW							1	
		. WASHER							1	
		. WASHER							1	
	-10	. COUPLING HALF							4	
	-11	. HOSE							4	
	-12	. CABLE ASSY							1	
	-13	. CABLE ASSY							1	
	-14	. CABLE ASSY							1	
	-15	. MANUAL, TECHNICAL, OPERATING.....							1	
		INSTRUCTIONS (77272)								
	-16	. CASE, TEST SET (94637)(VERTOL.....							1	
		SPEC CONT DWG AO2VS300-11								
		ATTACHING PARTS								
	-17	. SCREW							8	
	-18	. SCREW							4	
	-19	. SCREW							2	
		. WASHER							14	
		. RETAINER ASSY, OPERATING.....							1	
		INSTRUCTIONS								
	-20	. . CLIP ASSY							3	
		ATTACHING PARTS								
	-21	. . NUT							1	
		. . . PIN, CRES QQ-S763 CL 321.....							1	
		COND A 0.031 X 0.04								
		. . . CLIP							1	
	-22	. . FRAME ASSY							1	
		ATTACHING PARTS								
	-23	. . SCREW							10	
		. . NUT							10	
		. . WASHER							20	
	-24	. . SPACER							2	
		. . RETAINER ASSY							1	
	-25	. . . PIN, HINGE							1	
	-26	. . HINGE, HALF,3.5 IN							1	

GROUP ASSEMBLY PARTS LIST

FIGURE AND INDEX NO.	PART NUMBER	NOMENCLATURE 1 2 3 4 5 6 7	QTY PER ASSY	USABLE ON CODE
9-1		(MAKEFR MS20257YP4)		
-27		. . . SPRING	1	
-28		. . . PLATE	1	
		ATTACHING PARTS		
		. . . RIVET	3	
-29		. . . HINGE, HALF, 3.5 IN	1	
		(MAKEFR MS20257XP4)		
-30		. . . RETAINER	1	
-31		. . PIN, HINGE	2	
-32		. . HINGE, HALF, 6.5 in	2	
		(MAKEFR MS20257XP5)		
		. . PLATE ASSY, LATCH LH	1	
-33		. . PLATE ASSY, LATCH RH	1	
-34		. . . HINGE, HALF, 6.5 IN	1	
		(MAKEFR MS20257YP5)		
		ATTACHING PARTS		
		. . . RIVET	6	
-35		. BUTTON, LATCH	2	
		. . . LATCH ASSY	2	
-36	 LATCH	1	
-37	 PIN, HINGE	1	
-38		. . . SPRING	2	
-39		. LATCH PLATE, LH	1	
		LATCH PLATE, RH	1	
		. PLATE ASSY, LATCH LH	1	
-40		. PLATE ASSY, LATCH RH	1	
-41		. . PIN, GUIDE	2	
-42		. . RETAINER, LATCH LH	1	
		. . RETAINER, LATCH RH	1	
-43		. RECEPTACLE (77820)	1	
-44		. RECEPTACLE (77820)	1	
-45		. RECEPTACLE (77820)	1	
		ATTACHING PARTS		
		. SCREW	4	
		. NUT	4	
		. WASHER	4	
-46		. JACK	58	
		. JACK	1	
-47		. CONNECTOR, RECEPTACLE(77272).....	1	
-48		. CONNECTOR, RECEPTACLE(77272).....	1	
-49		. CONNECTOR, RECEPTACLE(77272).....	1	
		ATTACHING PARTS		
		. SCREW	2	
		. NUT	2	
		. WASHER	2	
-50		. SWITCH, MODIFIED ROTARY.....	1	
-51		. METER, ELECTRIC	1	
-52		. SWITCH, SINGLE-POLE TOGGLE	1	
-53		. SWITCH, DOUBLE-POLE TOGGLE.....	1	
-54		. METER, YAW AXIS	1	
-55		. KNOB, CONTROL	4	

GROUP ASSEMBLY PARTS LIST

FIGURE AND INDEX NO.	PART NUMBER	NOMENCLATURE 1 2 3 4 5 6 7	QTY PER ASSY	USABLE ON CODE
9-1		ATTACHING PARTS		
	-56	. SETSCREW	2	
		. RESISTOR, MOD VARIABLE	1	
		. RESISTER, MOD VARIABLE ALT	1	
		FOR A02V3075-1)		
		ATTACHING PARTS		
		. NUT	1	
		. WASHER	1	
	-57	. LIGHT ASSY, INDICATOR	1	
		LIGHT, INDICATOR	1	
		AMP	1	
	-58	. SWITCH, PUSH	1	
	-59	. METER, ROLL AXIS	1	
	-60	. SWITCH, SINGLE-POLE TOGGLE	1	
	-61	. LIGHT ASSY, INDICATOR	2	
		. LIGHT, INDICATOR	1	
		. LAMP	1	
	-62	. CIRCUIT BREAKER	2	
	-63	. METER, PITCH AXIS	1	
	-64	. PLATE, INSTRUCTION	1	
	-64A	. PLATE	1	
		ATTACHING PARTS		
	-64B	. SCREW	4	
		. NUT	4	
		. WASHER	4	
	-65	. SWITCH, MODIFIED ROTARY.....	1	
	-66	. BRACKET, SWITCH	1	
		ATTACHING PARTS		
	-67	. SCREW	4	
		. NUT	4	
	-68	. COUPLING HALF	4	
		ATTACHING PARTS		
		. NUT	1	
		. WASHER	1	
	-69	. GAGE, SIDESLIP AIR	1	
	-70	. GAGE, AIRSPEED AIR	1	
		ATTACHING PARTS		
		. SCREW	3	
		. WASHER	3	
		. CLAMP(SUP-W A02VS301 GAGES).....	6	
		ATTACHING PARTS		
		. NUT	1	
		. WASHER	1	

FIGURE AND INDEX NO.	PART NUMBER	NOMENCLATURE							QTY PER ASSY	USABLE ON CODE
		1	2	3	4	5	6	7		
- 71		•STUD						6		
- 72		•PLATE, INSTRUCTION ATTACHING PARTS							1	
		•SCREW							2	
		•NUT						2		
		•WASHER							2	
		X								
- 73		•PLATE, INSTRUCTION							1	
- 74		•PLATE, INSTRUCTION							1	
- 75		•PLATE, INSTRUCTION							1	
- 76		•PLATE, IDENTIFICATION							1	

FIGURE AND INDEX NO.	PART NUMBER	NOMENCLATURE							QTY PER ASSY	USABLE ON CODE
		1	2	3	4	5	6	7		
9-1 - 77		•PLATE, INSTRUCTION ATTACHING PARTS							1	
		•SCREW							4	
		•NUT							4	
		•WASHER							4	
		X								
- 78		•PLATE, INSTRUCTION							1	
- 79		•PLATE, INSTRUCTION							1	
- 80		•PLATE, INSTRUCTION							1	
- 81		•PANEL, FRONT ATTACHING PARTS							1	
- 82		•SCREW							14	
		•NUT							14	
		•WASHER							14	
		X								
		•TY-RAP(59730) ATTACHING PARTS							4	
		•SCREW							1	
		•NUT							1	
		•WASHER							1	
		X								
		•TY-RAP(59730) ATTACHING PARTS							11	
		•SCREW							1	
		•NUT							1	
		•WASHER							1	
		X								
- 83		•HARNESS ASSY							1	
		••SPLICE, BUTT(00779)							2	
		••TERMINAL, LUG(0779)							9	
- 84		•VALVE ASSY, DIFFERENTIAL PRESSURE REGULATING ATTACHING PARTS							2	
- 85		•SCREW							4	
- 86		••COVER ATTACHING PARTS							1	
- 87		•SCREW							4	
- 88		••ROTOR							1	
- 89		••SPRING, PRELOAD(00141)							1	
- 90		••HOUSING, VALVE							1	
- 91		•BOLT							12	
- 92		•GASKET							24	
- 93		•ELBOW							12	
- 94		•TUBE ASSY							4	
		••SLEEVE							2	
		••NUT							2	
		••TUBE, RD SMLS, 5052-0 AL ALY WW-T-700/4 1/4 x 0.035 x 2.7							1	
- 95		•TEE							4	
- 96		•TUBE ASSY							2	
		••SLEEVE							2	
		••NUT							2	

FIGURE AND INDEX NO.	PART NUMBER	NOMENCLATURE							QTY PER ASSY	USABLE ON CODE
		1	2	3	4	5	6	7		
9-1		••TUBE,RD SMLS,5052-0 AL.....							1	
		ALY WW-T-700/4								
		1/4 X 0.035 X 11								
- 97		•TUBE ASSY							2	
		••SLEEVE							2	
		••NUT							2	
		••TUBE,RO SMLS,5052-0 AL.....							1	
		ALY WW-T-700/4								
		1/4 x 0.035 X 5								
- 98		•TUBE ASSY							2	
		••SLEEVE							2	
		••NUT							2	
		••TUBE,RD SMLS,5052-0 AL.....							1	
		ALY WW-T-700/4								
		1/4 X 0.035 X 5								
- 99		•TUBE ASSY							1	
		••SLEEVE							2	
		••NUT							2	
		••TUBE,RF SMLS,5052-0 AL.....							1	
		ALY WW-T-700/4								
		1/4 X 0.035 X 12								
-100		TUBE ASSY							2	
		••SLEEVE							2	
		••NUT							2	
		••TUBE,RD SMLS,5052-0 AL.....							1	
		ALY WW-T-700/4								
		1/4 X 0.035 X 12								
-101		TUBE ASSY							1	
		••SLEEVE							2	
		••NUT							2	
		••TUBE,RD SMLS,5052-0 AL.....							1	
		ALY WW-T-700/4								
		1/4 X 0.035 X 8								
-102		TUBE ASSY							1	
		••SLEEVE							2	
		••NUT							2	
		••TUBE,RD SMLS,5052-0 AL.....							1	
		ALY WW-T-700/4								
		1/4 X 0.035 X 7								
-103		•NUT							2	
-104		•UNION							2	
-105		•TUBE ASSY							1	
		••SLEEVE							2	
		••NUT							2	
		••TUBE,RD SMLS,50S2-0 AL.....							1	
		ALY WW-T-700/4								
		1/4 X 0.035 X 6								
-106		•TUBE ASSY							1	
		••SLEEVE							2	
		••TUBE,RD SMLS,5052-0 AL.....							1	
		ALY WW-T-700/4								
		1/4 X 0.035 X 6								
		•NIPPLE							2	
-107		•BRACKET,PUMP SUPPORT.....							1	

FIGURE AND INDEX NO.	PART NUMBER	NOMENCLATURE							QTY PER ASSY	USABLE ON CODE
		1	2	3	4	5	6	7		
9-1		ATTACHING PARTS								
	-108	•SCREW						2		
		•SCREW						2		
		•NUT(U/W AN515C8R71							2	
		•NUT(U/W AN515C6R6)							2	
		•WASHER(U/W AN515C8R71							2	
	-109	•PUMP ASSY,AIR(241231							1	
		ATTACHING PARTS								
	-110	•SCREW						2		
		•NUT						2		
		•WASHER							2	
X	111	•PAN,BOTTOM							1	
		ATTACHING PARTS								
	-112	•SCREW						15		
		•NUT						15		
		•WASHER							15	
		X								
	-113	•TRANSFORMER(02640)							1	
		ATTACHING PARTS								
		•NUT						2		
		•WASHER							2	
		X								
	-114	•BRACKET							1	
		ATTACHING PARTS								
	-115	•SCREW						4		
		•NUT						4		
		X								
	-116	•0100E196214)							1	
	-117	•RETAINFR,COMPONENT CARDS							1	
		ATTACHING PARTS								
	-118	•SCREW						2		
		•WASHER							2	
X										
	-119	•RETAINER,COMPONENT CARDS							1	
		ATTACHING PARTS								
	-120	•SCREW						2		
		•WASHER							2	
	-121	•COMPONENT ASSY,ACTUATOR							3	
		SIMULATOR PRINTED CIRCUIT								
		(SEE FIG. 9-2)								
	-122	•COMPONENT ASSY,PRINTED							REF	
		CIRCUIT D(SEE FIG. 9-2)								
	-123	•COMPONENT ASSY,PRINTED							REF	
		CIRCUIT E(SEE FIG. 9-2)								
	-124	•COMPONENT ASSY,PRINTED							REF	
		CIRCUIT F(SEE FIG. 9-2)								
	-125	•CARD ASSY,AMPLIFIER PRINTED							REF	
		CIRCUIT(SEE FIG. 9-2)								
	-126	•CONNECTOR,RECEPTACLE(12357)							3	
		ATTACHING PARTS								
	-127	•NUT						2		
		•WASHER							2	
		X								

FIGURE AND INDEX NO.	PART NUMBER	NOMENCLATURE							QTY PER ASSY	USABLE ON CODE
		1	2	3	4	5	6	7		
9-1	-128	•CONNECTOR,RECEPTACLE(77272)							1	
	-129	•CONNECTOR,RECEPTACLE(77272)							1	
	-130	•CONNECTOR,RECEPTACLE(77272)							1	
	-131	•CONNECTOR,RECEPTACLE(77272)							1	
		ATTACHING PARTS								
	-132	•SCREW							2	
		•NUT							2	
		X								
		•TERMINAL (71468)							3	
	-133	•GROMFT							5	
	-134	•BRACKET,CONNECTOR SUPPORT							1	
		ATTACHING PARTS								
	-135	•SCREW							8	
		•NUT							8	
		•WASHER							8	
		X								
	-136	•PANEL,CONNECTOR SUPPORT							1	
		ATTACHING PARTS								
	-137	•SCREW							7	
		•NUT							7	
		•WASHER							7	
		X								
	-138	•BRACKET							1	
		ATTACHING PARTS								
	-139	•SCREW							2	
		•NUT							2	
		•WASHER							2	
		X								
	-140	•PAN,SIDE RH							1	
		ATTACHING PARTS								
	-141	•SCREW							6	
		•NUT							6	
		•WASHER							6	
		X								
	-142	•PAN ASSY							1	
		ATTACHING PARTS								
	-143	•SCREW							6	
		•NUT							6	
		•WASHER							6	
		X								
		••NUT ,PLATE							4	
		ATTACHING PARTS								
		••RIVET							2	
		X								
		••PAN							1	
	-144	•PAN, REAR							1	
	-145	•PAN,FRONT							1	
	-146	•BOX ASSY, ADAPTER							1	
		(SEE FIG 9-3)								

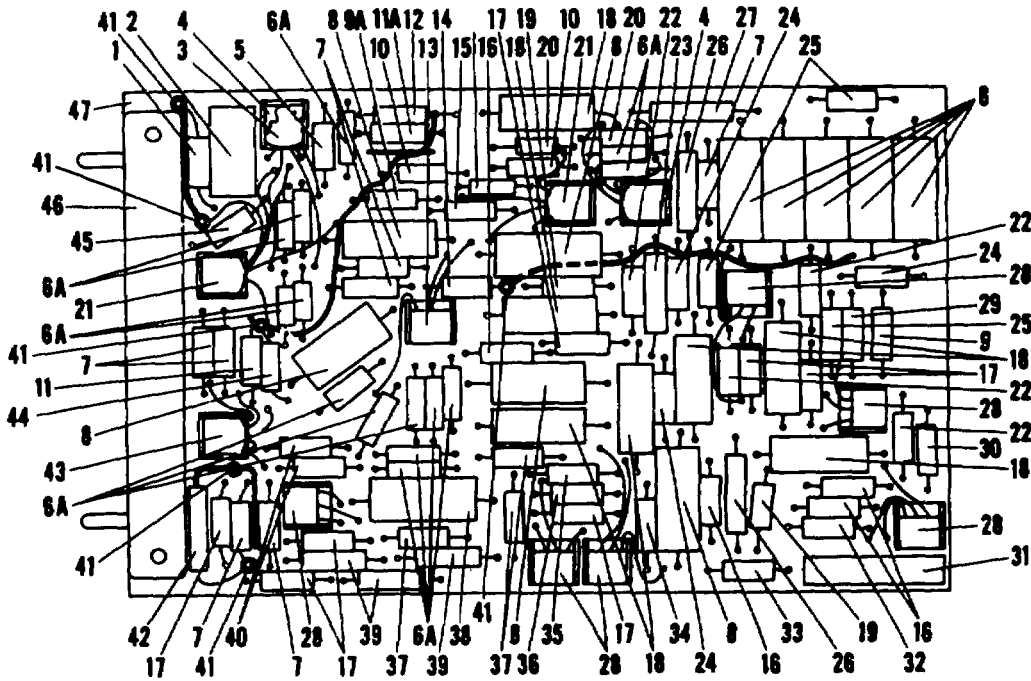
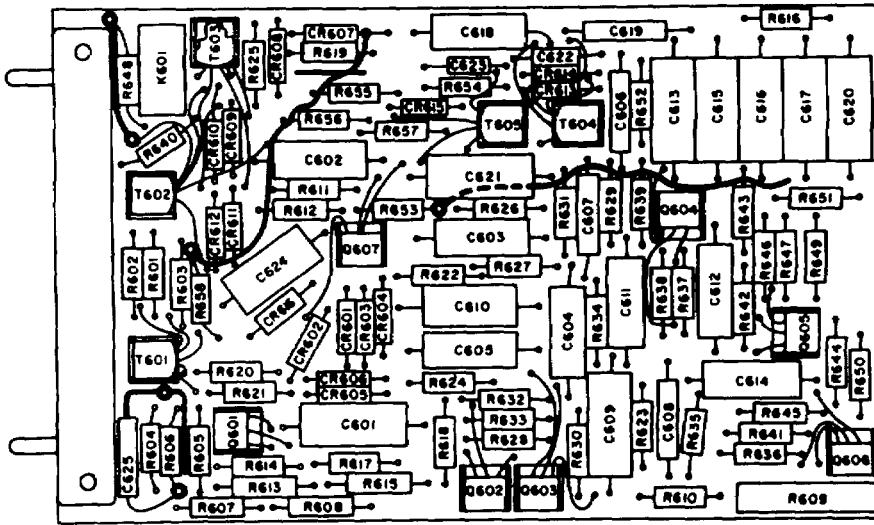

A02-5-425

FIGURE 9-2. SAS BENCH TEST SET COMPONENT BOARDS (SHEET 1)

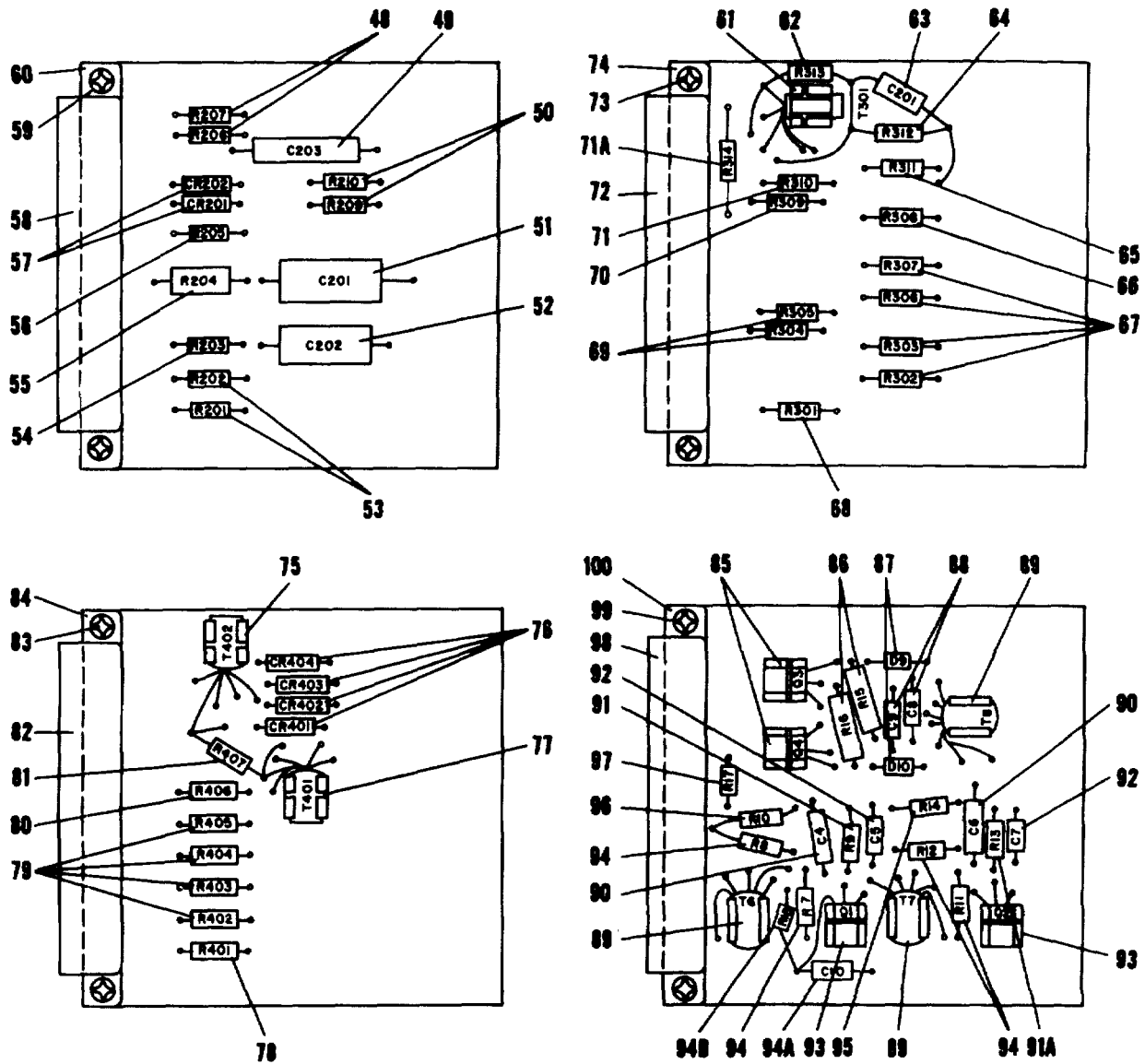

A02-5-428

FIGURE 9-2. SAS BENCH TEST SET COMPONENT BOARDS (SHEET 2)

FIGURE AND INDEX NO.	PART NUMBER	NOMENCLATURE							QTY PER ASSY	USABLE ON CODE
		1	2	3	4	5	6	7		
9-2		COMPONENT ASSY, ACTUATOR.....							REF	
		SIMULATOR PRINTED CIRCUIT (SEE FIG. 9-1)								
		• RESISTOR, 8.2-K(MIL-R-11/3)							AR	
		• RESISTOR, 7.5-K(MIL-R-11/3)							AR	
		• RESISTOR, 6.8-K(MIL-R-11/3)							AR	
		• RESISTOR, 6.2-K(MIL-R-11/3)							AR	
		• RESISTOR, 5.6-K(MIL-R-11/3)							AR	
		• RESISTOR, 5.1-K(MIL-R-11/3)							AR	
		• RESISTOR, 4.7-K(MIL-R-11/3)							AR	
		• RELAY, 24-VOC1999281							1	
-2		• SHIELO(80223)							5	
-3		• TRANSFORMER(80223)							2	
-4		• RESISTOR, 100-OHM (MIL-R-11/3)							1	
-5		• DIODE (77212)							14	
-6		• RESISTOR, 1-K(MIL-R-11/3)							7	
-7		• CAPACITOR, 4?-UF 35-VDC (77272)							10	
-8		• RESISTOR, 22-KIMIL-R-11/3)							2	
-9		• RESISTOR, 10-K (MIL-R- 11/3)							1	
-9A		• RESISTOR, 68-KIMIL-R-11/3)							2	
-10		• RESISTOR, 1.8-KIMIL-R-11/3)							2	
-11		• RESISTOR, 680-OHM (MIL-R- 11/3)							1	
-11A		• DIODE, ZENER(04713)							1	
-12		• TRANSISTOR196214)							1	
-13		• RESISTOR, 47-OHMIMIL-R-11/3).....							1	
-14		• RESISTOR, 2.4-K(MIL-R-11/3)							1	
-15		• RESISTOR, 4.7-K(MIL-R-11/3)							4	
-16		• RESISTOR, 56-KIMIL-R-11/3)							7	
-17		• CAPACITUR, 22-UF 35-VDC (77272)							7	
-18		• RESISTOR, 5.1-KIMIL-R-11/3)							2	
-19		• CAPACITOR, 1-UF 35-VOC (77272)							2	
-20		• TRANSFORMER180223)							2	
-21		• RESISTOR, 15-KIMIL-R-11/3)							4	
-22		• CAPACITOR, 0.11-UF 6-VOC (52689)							AR	
-23		• CAPACITOR, 0.13-UF 6-VDC (52689)							AR	
		• CAPACITOR, 0.16-UF 6-VOC (52689)							AR	
		• CAPACITOR, 0.19-UF 6-VUC (52689)							AR	
		• CAPACITOR, 0.23-UF 6-VDC (52689)							AR	
		• CAPACITOR, 0.28-UF 6-VDC (52689)							AR	
		• CAPACITOR, 0.34-UF 6-VOC (52689)							AR	
-24		• RESISTOR, 2.7-K(MIL-R 11/31)							3	
-25		• RESISTOR, 2.2-KIMIL-R 11/3)							3	
-26		• CAPACITOR, 2.3-UF 6-V DC (52689)							2	
-27		CAPACITOR, 0.5-UF 75-VOC (95017)							1	

FIGURE AND INDEX NO.	PART NUMBER	NOMENCLATURE							QTY PER ASSY	USABLE ON CODE
		1	2	3	4	5	6	7		
9-2	- 28	•TRANSISTOR(04713)							6	
	- 29	•RESISTOR,3.9-K(MIL-R-11/3)							1	
	- 30	•RESISTOR,22-OHM(MIL-R-11/3)							1	
	- 31	•RESISTOR,VARIABLE 2-KILOHM							1	
	- 32	•RESISTOR,6.Z-MEGOHM							1	
	- 33	(MIL-R-27208/3)								
	- 34	•RESISTOR, 9.1-K (MIL-R-11/3)							1	
	- 35	•RESISTOR, 1-K (MIL-R-11/3)							1	
	- 36	•RESISTOR, 3.6-K (MIL-R-11/3)							1	
	- 37	•RESISTOR, 27-K (MIL-R-11/3)							1	
	- 38	•RESISTOR, 10-K (MIL-R-11/3)							3	
	- 39	•CAPACITOR,330-UF 6-VDC							1	
	- 40	(77272)								
	- 41	•RESISTOR,PRECISION							3	
	- 42	10-K 1 PCT, 1/4-W (77272)								
	- 43	•RESISTOR 100-K (MIL-R-11/3)							2	
	- 44	•STANDOFF (71279)							6	
	- 45	•CAPACITOR, 9-UF 10-VDC							1	
	- 46	(05397)								
	- 47	•TRANSFORMER (80223)							1	
	- 48	•RESISTOR, 4.7- K							1	
	- 49	(MIL-R-11/3)								
	- 50	•RESISTOR,200-K(MIL-R-11/3)							1	
	- 51	•TUBING,VINYL(77272)							AR	
	- 52	•TUBING,PLASTIC(70331)							AR	
	- 53	•CONNECTOR,RIGHT ANGLE MALE.....							1	
	- 54	(12357)								
	- 55	ATTACHING PARTS								
	- 56	•NUT							2	
	- 57	•WASHER							2	
	- 58	X								
	- 59	CLAMP (99378)							12	
	- 60	ATTACHING PARTS								
	- 61	•RIVET(11279)							12	
	- 62	X								
	- 63	•PRINTED CIRCUIT BOARD							1	
	- 64	COMPONENT ASSY,PRINTED.....							REF	
	- 65	CIRCUIT D								
	- 66	•RESISTOR,2.7-K(MIL-R-11/3)							2	
	- 67	•CAPACITOR,0.25-UF 150-VDC							1	
	- 68	(95017)								
	- 69	•RESISTOR,330-OHM							2	
	- 70	(MIL-R-11/3)								
	- 71	•CAPACITOR,82-UF 50-VDC							1	
	- 72	(56289)								
	- 73	•CAPAC, TOR,47-UF 35-VOC							1	
	- 74	(77272)								
	- 75	•RESISTOR,1.2-MEGOHM							2	
	- 76	(MIL-R-11/3)								
	- 77	•RESISTOR,820-UHM							1	
	- 78	(MIL-R-11/3)								
	- 79	•RESISTOR,20-OHM(MIL-R-11/6)							1	
	- 80	•RESISTOR, 100-K 1 PCT, 1/4-2 (MIL-R-10509)							1	
	- 81	•DIODE							2	

GROUP ASSEMBLY PARTS LIST

C1, TM 11-6625-646-15

FIGURE AND INDEX NO.	PART NUMBER	NOMENCLATURE							QTY PER ASSY	USABLE ON CODE
		1	2	3	4	5	6	7		
9-2	- 58	•CONNECTOR,PLUG(77272).....							1	
		ATTACHING PARTS								
	- 59	•SCREW2								
		•NUT2								
		•WASHER2								
		X								
	- 60	•PRINTED CIRCUIT BOARD1							1	
		COMPONENT ASSY,PRINTED.....1							1	
		CIRCUIT E								
	- 61	•TRANSFORMER(80O223)1							1	
	- 62	•RESISTOR,3-KIMIL-R-11/31							1	
	- 63	•CAPACITOR,O.15-UF 100VOC1							1	
		(99515)								
	- 64	•RESISTOR, 4.7-K (MIL-R-11/3)1							1	
	- 65	•RESISTOR, 280-OHM, 1 PGT1							1	
		1/4-W (MIL-R-10509)								
	- 66	•RESISTOR, 10-OHM, 1 PCT1							1	
		1/4-W (MIL-R-10509)								
	- 67	•RESISTOR, I-K (MIL-R-11/3)4							4	
	- 68	•RESISTOR, 1.6-MEGOHM1							1	
		(MIL-R-11/3)								
	- 69	•RESISTOR, 82.5-K, 1 PCT1							1	
		1/4-W (MIL-R-10509)								
		•RESISTOR, 150-K, 1 PCT1							1	
		1/4-W (MIL-R-10509)								
	- 70	•RESISTOR, 5.49-K, 1 PCT1							1	
		1/4-W (MIL-R-10509)								
	- 71	•RESISTOR, 2-K, 1 PCT1							1	
		1/4-W (MIL-R-10509)								

FIGURE AND INDEX NO.	PART NUMBER	NOMENCLATURE							QTY PER ASSY	USABLE ON CODE
		1	2	3	4	5	6	7		
9-2 - 71.A		•RESISTOR, 39-K, 5 PCT, 1/2-W (77272)							1	
- 72		•CONNECTOR, PLUG (77272)							1	
		ATTACHING PARTS								
- 73		•SCREW2								
		•NUT2								
		•WASHER 2								
		X								
-74		•BOARD SUBASSY 1								
		CLAMP (99378) 1								
		ATTACHING PARTS								
		••RIVET (71279) 1								
		X								
		••STANDOFF (71279) 4								
		••PRINTED CIRCUIT BOARD 1								
		COMPONENT ASSY,PRINTED REF								
		CIRCUIT F								
- 75		•TRANSFORMER (802231) 1								
- 76		•DIODE (77272) 4								
- 77		•TRANSFORMER (80223) 1								
- 78		•RESISTOR, 390-K (MIL-R-11/31) 1								
- 79		• RESISTOR, 12-K (MIL-R-11/3) 4								
- 80		• RESISTOR, 130-K (MIL-R-11/3) 1								
- 81		• RESISTOR, 91-OHM (MIL-R-11/31) 1								
- 82		•CONNECTOR, PLUG (77272) 1								
		ATTACHING PARTS								
- 83		•SCREW2								
		•NUT2								
		•WASHER 2								
		X								
- 84		•BOARD SUBASSY 1								
		••CLAMP (99378) 2								
		ATTACHING PARTS								
		••RIVET (71279) 1								
		X								
		STANDOFF (71279) 2								

FIGURE AND INDEX NO.	PART NUMBER	NOMENCLATURE							QTY PER ASSY	USABLE ON CODE
		1	2	3	4	5	6	7		
9-2		••PRINTED CIRCUIT BOARD							1	
		CARD ASST,AMPLIFIER PRINTED.....							1	
		CIRCUIT								
	- 85	•TRANSISTOR (04713)							2	
	- 86	•RESISTOR, 15.1-K							2	
		(MIL-R-10509) (12697)								
	- 87	•DIODE (01281)							2	
	- 88	•CAPACITOR, 0.15-UF(56289)							2	
		•SHIELD 80223)							2	
	- 89	•TRANSFORMER (80223)							3	
	- 90	•CAPACITOR, 4.7-UF (56289)							2	
	- 91	•RESISTOR, 16-OHM PORM							AR	
		5PCT, 1/2-W (77272)								
		•RESISTOR, 18-OHM PORM							AR	
		5 PCT, 1/2-W (77272)								
		•RESISTOR, 20-OHM PORM							AR	
		5 PCT, 1/2-W (77272)								
		•RESISTOR, 22-OHM PORM							AR	
		5 PCT, 1/2-W (77272)								
		•RESISTOR, 24-OHM PORM							AR	
		5 PCT, 1/2-W (77272)								
		•RESISTOR, 27-OHM PORM							AR	
		5 PCT, 1/2-W (77272)								
		•RESISTOR, 30-OHM PORM							AR	
		5 PCT, 1/2-W (77272)								
		•RESISTOR, 33-OHM PORM							AR	
		5 PCT, 1/2-W (77272)								
		•RESISTOR, 36-OHM PORM							AR	
		5 PCT, 1/2-W (77272)								
		•RESISTOR, 39-OHM PORM.....							AR	
		5 PCT, 1/2-W (77272)								

FIGURE AND INDEX NO.	PART NUMBER	NOMENCLATURE 1 2 3 4 5 6 7	QTY PER ASSY	USABLE ON CODE
- 91 (continued)		<ul style="list-style-type: none"> •RESISTOR, 43-OHM PORM 5 PCT, 1/2-2 (77272) •RESISTOR, 47-OHM PORM 5 PCT, 1/2-W (77272) •RESISTOR, 51-OHM PORM 5 PCT, 1/2-W (77272) •RESISTOR, 56-OHM PORM 5 PCT, 1/2-W (77272) •RESISTOR, 62-OHM PORM 5 PCT, 1/2-W (77272) •RESISTOR, 68-OHM PORM 5 PCT, 1/2-W (77272) •RESISTOR, 75-OHM PORM 5 PCT, 1/2-W (77272) •RESISTOR, 82-OHM PORM 5 PCT, 1/2-W (77272) •RESISTOR, 91-OHM PORM 5 PCT, 1/2-W (77272) •RESISTOR, 100-OHM PORM..... 5 PCT, 1/2-W (77272) 	AR AR AR AR AR AR AR AR AR AR AR	
- 91A		<ul style="list-style-type: none"> •RESISTOR, 22-OHM PORM 5 PCT, 1/2-W (77272) 	AR	

GROUP ASSEMBLY PARTS LIST

C1, TM 11-6625-646-15

FIGURE AND INDEX NO.	PART NUMBER	NOMENCLATURE							QTY PER ASSY	USABLE ON CODE
		1	2	3	4	5	6	7		
- 92		•CAPACITOR,I-UF156289)							2	
- 92		•TRANSISTOR(95107)							2	
- 93		•RESISTOR,10-KIMIL-R-11/31.....							4	
- 94		•CAPACITOR, 0.47-UF (99515)							1	
- 94A										
- 94B		•RESISTOR, 1.2-K (MIL-R-11/3)							1	
- 95		•RESISTOR,2.7-K(MIL-R-11/3)							1	
- 96		•RESISTOR,3.3-K(MIL-R-11/3)							1	
- 97		•RESISTOR, 1-K (MIL-R-11/3)							1	
- 98		•CONNECTOR,PLUG							1	
		ATTACHING PARTS								
- 99		•SCREW							2	
		•NUT							2	
		•WASHER							2	
		•CLAMP (99378)							7	
		ATTACHING PARTS								
		•RIVET (71279)							1	
		X								
		•STAND-OFF (71279)							3	
- 100		•CARD,PRINTED CIRCUIT							1	

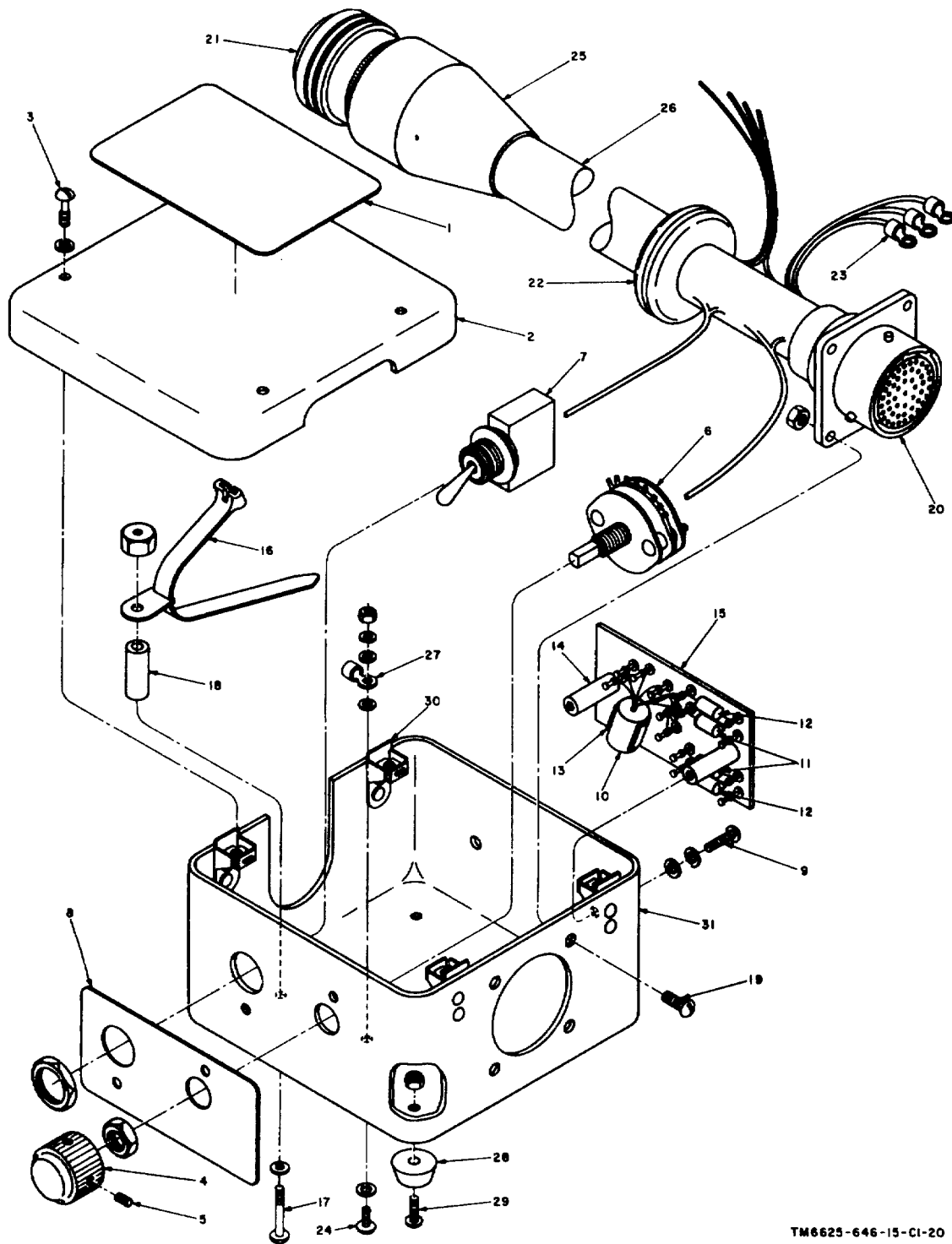

TM6625-646-15-C1-20

Figure 9-3. Box Assembly, Adapter.

FIGURE AND INDEX NO.	PART NUMBER	NOMENCLATURE							QTY PER ASSY	USABLE ON CODE
		1	2	3	4	5	6	7		
9-3		BOX ASSY, ADAPTER							REF	
	-1	. METALCAL							1	
	-2	. COVER							1	
		ATTACHING PARTS								
	-3	. SCREW							4	
		. WASHER							4	
		---- X ----								
	-4	. KNOB							1	
		ATTACHING PARTS								
	-5	. SETSCREW							2	
		---- X ----								
	-6	. SWITCH, ROTARY							1	
	-7	. SWITCH, TOGGLE							1	
	-8	. METALCAL							1	
		. COMPONENT ASSY							1	
		ATTACHING PARTS								
	-9	. SCREW							2	
		. WASHER							2	
		. WASHER, LOCK							2	
		---- X ----								

FIGURE AND INDEX NO.	PART NUMBER	NOMENCLATURE							QTY PER ASSY	USABLE ON CODE
		1	2	3	4	5	6	7		
9-3 (cont)										
-10		. .	TRANSFORMER (80223)					1	
-11		. .	RESISTOR, 4.87-K, 1 PCT,					2	
			1/10-W (MIL-R-10509/7)							
-12		. .	RESISTOR, 16.9-K; 1PCT,					2	
			1/10-W (MIL-R-10509/7)							
		. .	WIRE, SOLID, 26-AWG					AR	
			(QQ-W-00343/S)							
		. .	BOARD ASSY					1	
-13		. . .	CLIP 1							
			ATTACHING PARTS							
		. . .	RIVET 1							
			----X----							
		. . .	TERMINAL					9	
		. . .	TERMINAL					5	
-14		. . .	STANDOFF					2	
-15		. . .	BOARD					1	
		*	CABLE ASSY, ADAPTER					1	
			ATTACHING PARTS							
-16		. .	CABLE STRAP					1	

FIGURE AND INDEX NO.	PART NUMBER	NOMENCLATURE							QTY PER ASSY	USABLE ON CODE	
		1	2	3	4	5	6	7			
9-3 (cont)											
-17		.	SCREW						1		
		.	WASHER						1		
		.	NUT						1		
-18		.	SPACER						1		
-19		.	SCREW						4		
		.	NUT						4		
			----	X	----						
-20		..	CONNECTOR, RECEPTACLE.						1		
-21		..	CONNECTOR, PLUG						1		
-22		..	GROMMET						1		
-23		..	LUG, TERMINAL						3		
			ATTACHING PARTS								
-24		..	SCREW						1		
		..	WASHER						3		
		..	WASHER, LOCK						1		
		..	NUT						1		
			----	X	----						
-25		..	BOOT, HEAT SHRINKABLE						1		
-26		..	SLEEVE, HEAT SHRINKABLE						AR		

FIGURE AND INDEX NO.	PART NUMBER	NOMENCLATURE							QTY PER ASSY	USABLE ON CODE
		1	2	3	4	5	6	7		
9- 3 (cont)										
-26		. .	WIRE, INSULATED, NO. 20					AR	
			(MIL-W- 16878/1)							
		. .	BRAID, TUBULAR					AR	
		. .	ADHESIVE, EPOXY					AR	
-27		. .	LUG, TERMINAL					1	
-28		. .	BUMPER (70485)					4	
			ATTACHING PARTS							
-29		. .	SCREW				4		
		. .	NUT.				4		
		. .	BOX ASSY					1	
-30		. .	NUT, ANCHOR					4	
			ATTACHING PARTS							
		. .	RIVET					8	
			----X----							
-31		. .	BOX (19178)					1	

By Order of the Secretary of the Army:

Official:

J. C. LAMBERT,
Major General, United States Army,
The Adjutant General.

HAROLD K. JOHNSON,
General, United States Army,
Chief of Staff.

DISTRIBUTION:

To be distributed in accordance with DA Form 12-36 (Unclas) requirements for Direct and General Support Maintenance Literature for the CH-47A Aircraft.

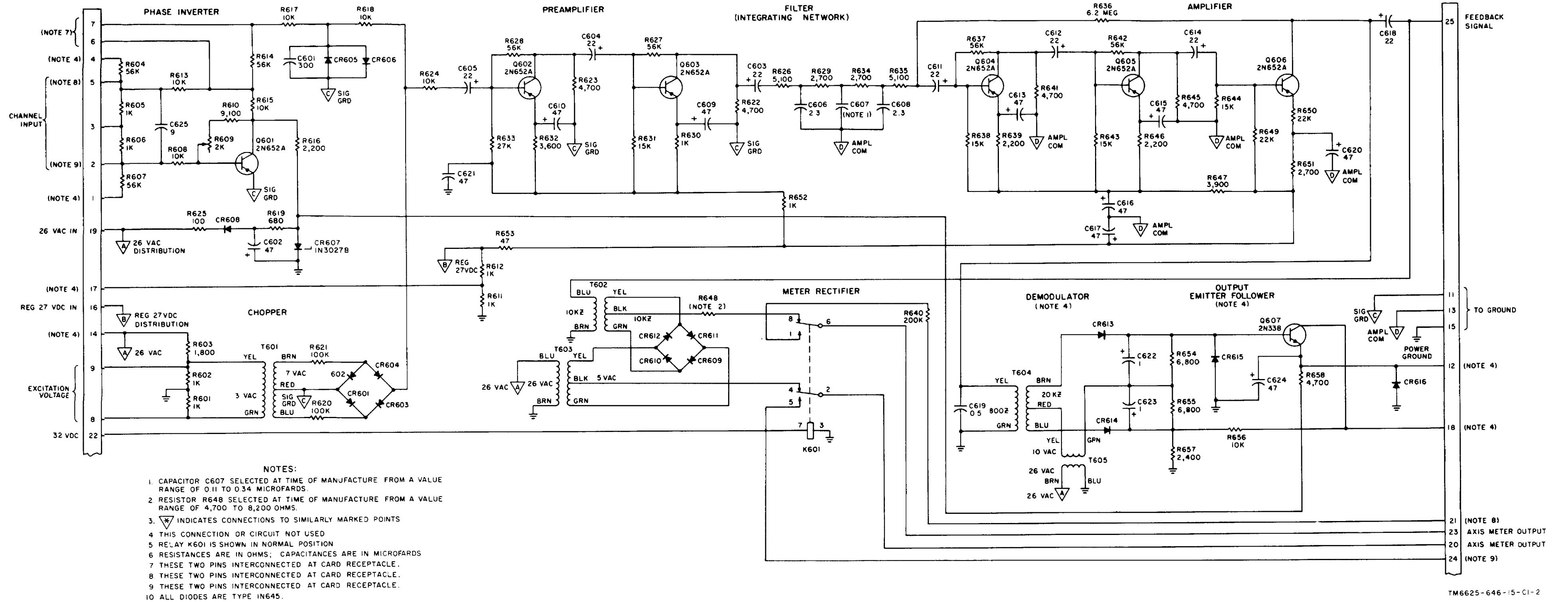
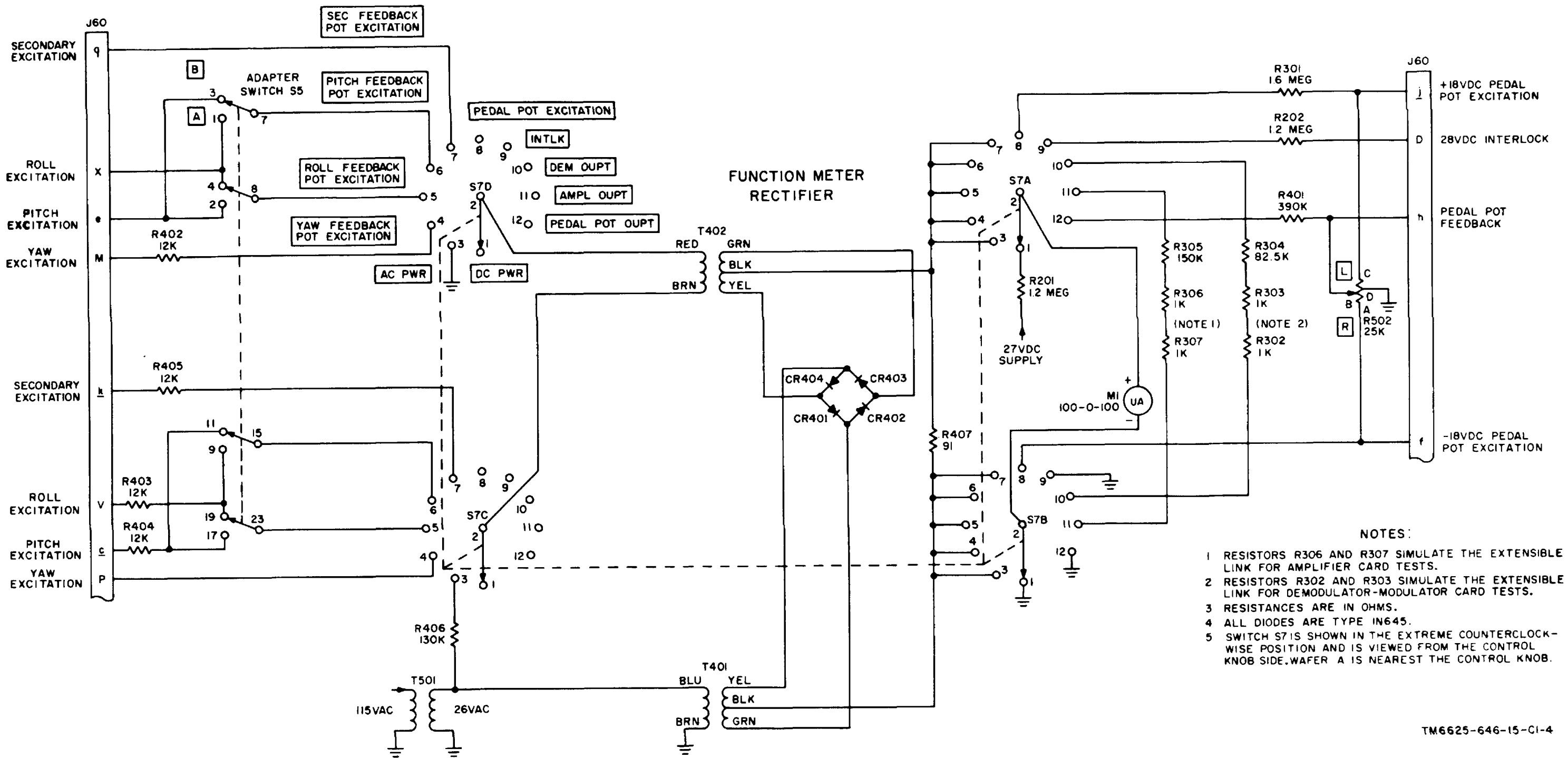

Figure 1-2. Actuator-simulator card schematic diagram.



TM6625-646-15-C1-4

Figure 1-4. Function meter circuit, simplified schematic

- NOTES:
1. [Symbol] INDICATES EQUIPMENT MARKING.
 2. THE ZENER DIODE IS TYPE 1N623A ALL OTHER DIODES ARE TYPE 1N645.
 3. RESISTANCES ARE IN OHMS, CAPACITANCES ARE IN MICROFARADS.
 4. SEE THE SCHEMATIC DIAGRAM OF THE ACTUATOR SIMULATOR CARD.
 5. [Symbol] INDICATES COMMON CONNECTION POINTS.
 6. SWITCH S7 IS SHOWN IN THE EXTREME COUNTER-CLOCKWISE POSITION AS VIEWED FROM THE CONTROL KNOB SIDE. WAFER A IS NEAREST THE CONTROL KNOB.
 7. SEE THE SCHEMATIC DIAGRAM OF THE SERVO AMPLIFIER CARD.

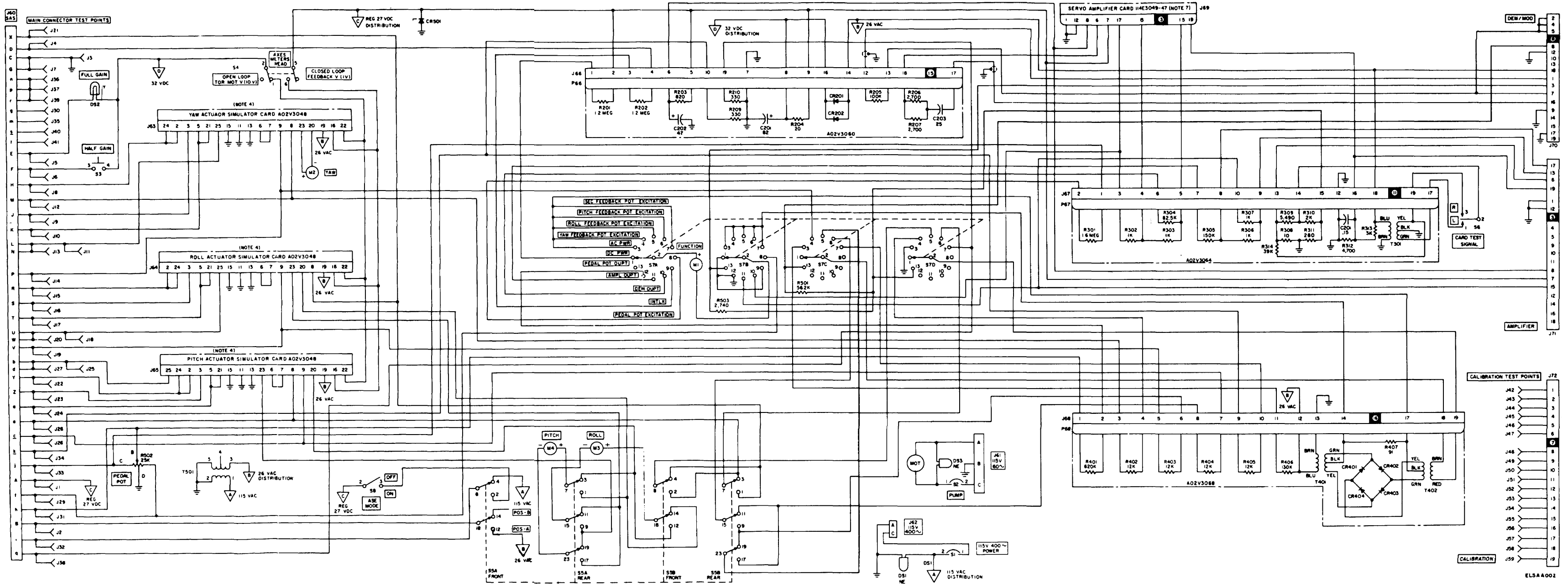

Figure 1-5. Test set schematic diagram

Change 4

ELSA A002

- NOTES:
- WIRE ROUTING AND IDENTIFICATION INFORMATION IS INTERPRETED AS FOLLOWS:
 - A THE NUMBER ADJACENT TO THE BASE LINE IDENTIFIES THE STATION TO WHICH THE WIRE RUNS.
 - B THE NUMBER PRECEDING THE DASH INDICATES THE COLOR OF THE WIRE:
 - 0 - BLACK
 - 1 - BROWN
 - 2 - RED
 - 3 - ORANGE
 - 4 - YELLOW
 - 5 - GREEN
 - 6 - BLUE
 - 7 - PURPLE OR VIOLET
 - 8 - GRAY
 - 9 - WHITE
 - THE LETTER, NUMBER, OR LETTER AND NUMBER WHICH FOLLOW THE DASH IDENTIFIES THE TERMINAL AT THE DESTINATION.
 - D PT INDICATES DIGITAL WIRING.
 - E ALL JUMPER WIRE IS COLOR NO. 9
 - THE CIRCLED NUMBER ON CARD CONNECTOR INDICATES GUIDE PIN LOCATION.
 - UNLESS OTHERWISE NOTED, ALL WIRING IS NO. 22, PLASTIC COVERED, STRANDED COPPER.
 - REFER TO WIRING DIAGRAM OF ACTUATOR SIMULATOR CARD.
 - REFER TO WIRING DIAGRAM OF THE AMPLIFIER CARD.

GROUND LUGS

12	0-5	21
	0-13	21
	0-11	21
23	0-15	10
	0-13	0
	0-11	0
27	0-15	11
	0-13	11
	0-11	11
28	0-13	50
	0-17	50
29	0-13	51
	0-12	42
	0-7	22
43	0-12	9
	0-12	57
	0-1	57
44	0-12	19
	0-1	19
52	0-5	41
	0-D	17
53	0-3	8
	0-1	7
	0-B	55
58	SHIELD-1	9
	SHIELD-16	9
59	0-17	9

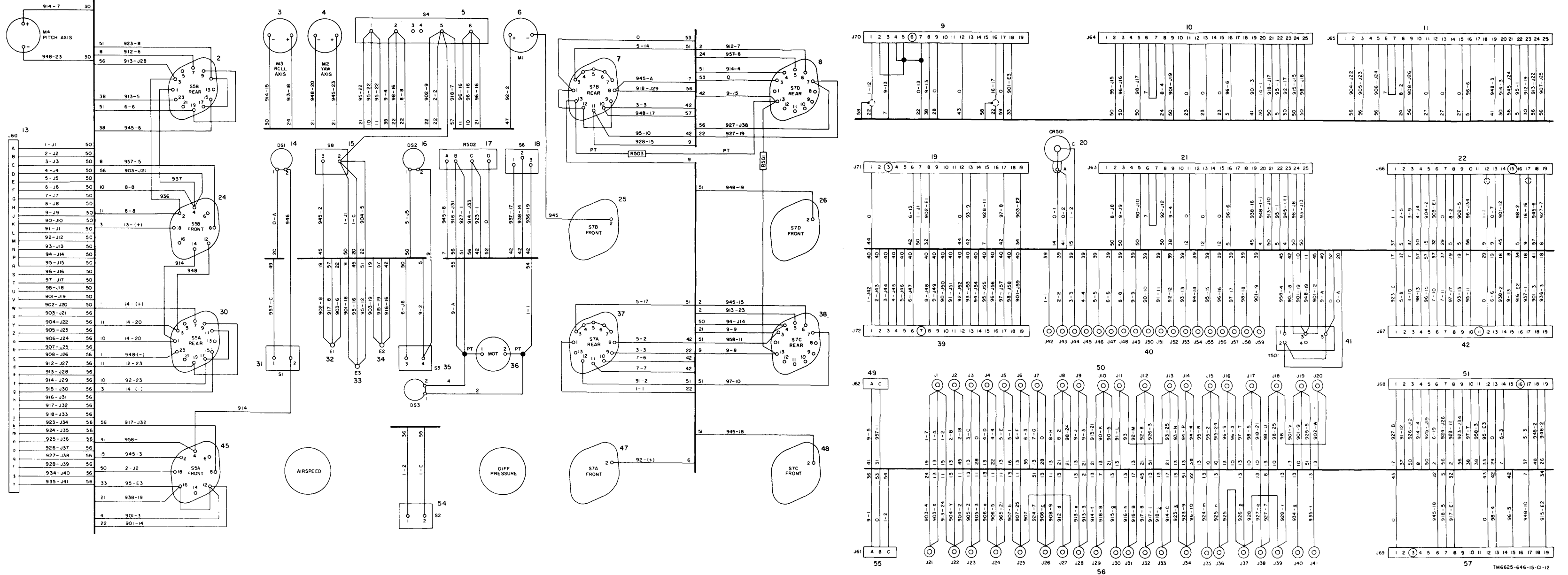

Figure 6-1. SAS bench test set, wiring diagram

RECOMMENDED CHANGES TO EQUIPMENT TECHNICAL PUBLICATIONS



THEN...JOT DOWN THE DOPE ABOUT IT ON THIS FORM. CAREFULLY TEAR IT OUT, FOLD IT AND DROP IT IN THE MAIL.

SOMETHING WRONG WITH PUBLICATION

FROM: (PRINT YOUR UNIT'S COMPLETE ADDRESS)

DATE SENT

PUBLICATION NUMBER

PUBLICATION DATE

PUBLICATION TITLE

BE EXACT PIN-POINT WHERE IT IS

PAGE NO.	PARA-GRAPH	FIGURE NO.	TABLE NO.

IN THIS SPACE, TELL WHAT IS WRONG AND WHAT SHOULD BE DONE ABOUT IT.

PRINTED NAME, GRADE OR TITLE AND TELEPHONE NUMBER

SIGN HERE

The Metric System and Equivalents

Linear Measure

1 centimeter = 10 millimeters = .39 inch
 1 decimeter = 10 centimeters = 3.94 inches
 1 meter = 10 decimeters = 39.37 inches
 1 dekameter = 10 meters = 32.8 feet
 1 hectometer = 10 dekameters = 328.08 feet
 1 kilometer = 10 hectometers = 3,280.8 feet

Weights

1 centigram = 10 milligrams = .15 grain
 1 decigram = 10 centigrams = 1.54 grains
 1 gram = 10 decigrams = .035 ounce
 1 decagram = 10 grams = .35 ounce
 1 hectogram = 10 decagrams = 3.52 ounces
 1 kilogram = 10 hectograms = 2.2 pounds
 1 quintal = 100 kilograms = 220.46 pounds
 1 metric ton = 10 quintals = 1.1 short tons

Liquid Measure

1 centiliter = 10 milliliters = .34 fl. ounce
 1 deciliter = 10 centiliters = 3.38 fl. ounces
 1 liter = 10 deciliters = 33.81 fl. ounces
 1 dekaliter = 10 liters = 2.64 gallons
 1 hectoliter = 10 dekaliters = 26.42 gallons
 1 kiloliter = 10 hectoliters = 264.18 gallons

Square Measure

1 sq. centimeter = 100 sq. millimeters = .155 sq. inch
 1 sq. decimeter = 100 sq. centimeters = 15.5 sq. inches
 1 sq. meter (centare) = 100 sq. decimeters = 10.76 sq. feet
 1 sq. dekameter (are) = 100 sq. meters = 1,076.4 sq. feet
 1 sq. hectometer (hectare) = 100 sq. dekameters = 2.47 acres
 1 sq. kilometer = 100 sq. hectometers = .386 sq. mile

Cubic Measure

1 cu. centimeter = 1000 cu. millimeters = .06 cu. inch
 1 cu. decimeter = 1000 cu. centimeters = 61.02 cu. inches
 1 cu. meter = 1000 cu. decimeters = 35.31 cu. feet

Approximate Conversion Factors

<i>To change</i>	<i>To</i>	<i>Multiply by</i>	<i>To change</i>	<i>To</i>	<i>Multiply by</i>
inches	centimeters	2.540	ounce-inches	Newton-meters	.007062
feet	meters	.305	centimeters	inches	.394
yards	meters	.914	meters	feet	3.280
miles	kilometers	1.609	meters	yards	1.094
square inches	square centimeters	6.451	kilometers	miles	.621
square feet	square meters	.093	square centimeters	square inches	.155
square yards	square meters	.836	square meters	square feet	10.764
square miles	square kilometers	2.590	square meters	square yards	1.196
acres	square hectometers	.405	square kilometers	square miles	.386
cubic feet	cubic meters	.028	square hectometers	acres	2.471
cubic yards	cubic meters	.765	cubic meters	cubic feet	35.315
fluid ounces	milliliters	29.573	cubic meters	cubic yards	1.308
pints	liters	.473	milliliters	fluid ounces	.034
quarts	liters	.946	liters	pints	2.113
gallons	liters	3.785	liters	quarts	1.057
ounces	grams	28.349	liters	gallons	.264
pounds	kilograms	.454	grams	ounces	.035
short tons	metric tons	.907	kilograms	pounds	2.205
pound-feet	Newton-meters	1.356	metric tons	short tons	1.102
pound-inches	Newton-meters	.11296			

Temperature (Exact)

°F	Fahrenheit temperature	5/9 (after subtracting 32)	Celsius temperature	°C
----	---------------------------	-------------------------------	------------------------	----

